



# NATIONAL STOCKYARD SYSTEMS



Australia's Best  
Stock Yards

designed by stockmen for stockhandlers

**Eighth Edition**



# Mission Statement

"To develop, manufacture and market a range of stock handling equipment that optimises value for clients through increased stock flow and minimal stress for operator and stock.

Natural stock behaviour will dictate product design and client value will be maximised via cost / safe stock throughput parameter ratios.

National Stockyard Systems does not seek to provide a solution for every requirement, but does seek to provide a product that offers superior value and performance in chosen fields".

---

**All products are 100% manufactured at our Rutherford factories using Australian Made Steel.**

---

## **NATHAN ELLICOTT**

*Director - National Stockyards Pty Ltd  
Sales and Production Control*

*Tel: 02 4932 1363 Mobile 0431 163 770*

Nathan grew up working on the family lucerne farm. He has done mustering and stock work on properties in regional NSW.

*"I worked for National Stockyard Systems Pty Ltd for 11 years as manufacturing and operations manager. I look forward to continuing this role and designing new products."*

## **SIMON BURRELL**

*Director - National Stockyards Pty Ltd  
Sales and Marketing*

*Tel: 02 4932 1363 Mobile 0425 315 913*

Simon grew up on the family beef property running 400 breeders. After attending Orange Ag College Simon went contract farming in the Moree district before returning home.

*"I enjoy client interaction, experiencing the diversity of our customer operations and seeing first hand seasonal changes and differing land types across Eastern Australia."*







**ARTHUR JAMES**  
**Sales and Deliveries**  
Mobile 0429 605 442

Arthur grew up on the family farm and spent weekends on a farm in Merriwa, after leaving school Arthur worked on properties in the Moree District.

*"I like working at National Stockyards. It puts me back on the land which is my passion. I enjoy seeing different parts of Australia, and, meeting all types of people with similar interests to me."*



## The Experienced Field Day Sales Team



**KEN BURKINSHAW "Amaroo" Lockhart**  
Mobile 0427 557 025

*"We needed 2 sets of yards. I did my homework very carefully before deciding on National Stockyard Systems. After purchasing the yards Murray approached me and asked if I was able to assist with sales at some Field Days.*

*I don't see it as selling but it is a pleasure to have interaction with a great team of people and demonstrating products I believe in".*



**DYLAN WADE "Ellavale" Dungog**  
Mobile 0408 624 489

Dylan grew up on the family farm at Dungog. Dylan runs his own cattle enterprises, competes in many dog trials and is heavily involved in the local community

*"It is a pleasure to communicate with so many different people. Everybody has a different operation and a different story to tell. I learn a lot from them and I enjoy using my knowledge to assist in making their stock work easier."*



**MARK CLIFTON "Kia-Ora" Gunnedah**  
Mobile 0458 432 318

Mark is a 5th generation grazier. Mark grew up on the family farm at Muswellbrook. Mark and Tina operate 2 farms in the Gunnedah area running sheep and cattle. Mark also has a side line earthmoving business. Mark and Tina are keen horse people and are greatly involved in the local community.

*"We purchased a complete set of yards in 2006 and we really enjoy processing our cattle through the yards".*

© Copyright - National Stockyard Systems

Copying of this work in whole or in part may not be carried out without the express written permission of the Copyright Proprietor.



# Important Information

**WE WELCOME FEEDBACK ON ANY OF THE FOLLOWING FACTS AND ENCOURAGE YOU TO CONTACT US IF YOU REQUIRE FURTHER CLARIFICATION.**

- **Our patented bolt together system will handle uneven or sloping ground.**  
A 3.2 metre panel can rise or fall over 4 inches via our slotted holes. A rise or fall of over 8 inches is easy with our extender cleats. **Also, impact is spread over adjacent panels if a beast hits hard.**
- **The steel we use is Grade 450 (very high tensile and gal inside and out)**  
A 1.6mm wall has the same strength as 2.1mm wall in normal steel, and a 2.0mm wall has the same strength as 2.6mm wall in normal steel. **Oval rail minimises bruising.**
- **The bolt together system will eliminate rattle noise, is stronger than pins, acts a theft deterrent and does not take much longer to erect than a pin together system.**
- **Alternative joining systems utilizing cleats and pins where the top cleat is below the top of the panel has resulted in many broken legged horses and cattle.**
- **The centre cleat on our joining system transfers impact from the gate slam catch post to the 1, or often, 2 adjacent panel posts.** This prevents the slam catch popping from the keeper under impact or pressure.
- **If a gate does not swing back to lay flat against the adjacent panel, then it is very easy for the gate hinges to be broken, or the gate hinge to be torn off the post (due to the massive fulcrum effect).**
- **Our pricing is GST inclusive** (as per the law).
- **The longer panels we use result in the erected yards being bigger than they appear on paper.** Also we attempt

to provide safe working capacities (based on 2 tooth steers). (A cow and calf unit will require double that area). **We do not quote tight holding capacities** which leave no room for processing cattle.

- **The automatic stopper/s on our gates (2 per gate on medium and heavy yards) prevent gate twist and eliminates the gate being pushed through when drafting.** (Our gate folds back 180 degrees one way and the automatic stopper can be manually over ridden to allow 100 degrees swing the other way). **The slam catch pin rotates back behind the gate post so as to be non bruise when drafting.** Also pulling a slam catch gate behind you to close it, when walking through yards, is infinitely quicker than stopping and turning to latch a conventional chain or drop bolt closing gate.
- **The slide gates and calf panels have extra rails to prevent heads getting through the rails.** Also we provide an extra rail option in our working race.
- **Manways are included in most plans, ground pins are included in all yards and concretable spigots with sleeves are included with all ramps.** These are all often optional extras with other suppliers.
- **We are often asked by resellers to sell through them but, we only sell direct.** Thus, by purchasing direct, the end user is receiving practical advice and a superior product at a lower cost than going through a reseller. *Some resellers push clients into products they make the most margin on, rather than the most suitable product.*
- **Ground Pins, Bolts & Caps are included in all pricing.**

## 2009 Award of Excellence for the Hicks Draft / Baulk Combination.

This product has since been adapted into more product lines that will enhance your drafting.

## 2011 Award of Excellence for our Sheep Yards.

The judges commented that the award was for the whole system. Being the entry, the processing, and exiting the yards.

## 2013 Award of Excellence for our Headmaster Head Bail.

This is the only head bail on the market that has true mechanical advantage – initial speed of closing when first activated and then power when closing on an animal's neck. Combined with other features on our extensive range of cattle crushes, results in us being able to supply a quality crush to match your requirements.

## 2014 Henty Machine of the Year Runner Up for our Top End + 200 Cattle Crush.

The features of this crush propel it to the best available for stud animal husbandry.

## 2016 Award of Excellence for our Remote Livestock Handling Equipment.

The system features a fully mobile - remote control unit (worn on the waist freeing both hands) with toggle control on the head bail and crush squeeze. The toggle or joystick control imitates manual operation enabling the head bail and squeeze to be incrementally opened or closed. The system will cater for a 5 way draft, head bail operation, squeeze, crush entry, weigh box entry and race entry. In addition a synchronised button controller allows the person loading the race etc. to also open and close the race slide gates. A huge advantage is that the drafter, crush, weigh box and slide gates can still be operated manually if there is a power outage etc. or an EID tag needs replacing prior to loading. Quite simply there is no better air or hydraulic system available.

## 2017 Award of Excellence for our Solar Powered Drafting using Smart Phone or Tablet.

No power or air is required. Your Smart Phone connects via bluetooth to the drafter via a free app. This does the same job as an air draft but is a fraction of the cost.





# Supplying quality Australian made cattle crushes using Australian made steel



## THE NEW “HEADMASTER HEADBAIL”™

### The undisputed dux of all headbails

This new head bail is on our complete range of crushes  
Until now most head bails had a limited mechanical advantage.

Mechanical advantage is vital when an 80 kg person is trying to restrain a 600 kg animal.

Traditional ratchet locking head bails only lock in increments of 20 - 40 mm or so. This allows a big neck animal to suck back, or allows excessive head movement which can be dangerous to both animal and operator.

Our new head bail has closing down to 6 mm increments with almost zero suck back (suck back can be a problem with slide locks and all traditional ratchet locks).

The new NSS head bail combines approaching over center in 3 differing closing positions with the safety of a gravity ratchet lock. In addition there is a mechanical advantage of up to 5 to 1 which means that an 80kg person can apply up to 400kgs of pressure. These 2 advantages combine with closing increments down to 6mm, and, quick release push – pull dual operating handles on all crushes.

Over 5 years and thousands of hours have been invested in the research, development and field testing of this revolutionary patent pending head bail.

**Quite simply there is no other head bail on the market that can approach this head bail for performance.**



As with all National Stockyard Systems products our crushes are 100% made in Australia. Crush designer Gerald Hicks is delighted with the performance of the new head bail during commercial testing.

**The Award of Excellence recognises new, innovative design and manufacture of machinery, and equipment designed for use in the Australian agricultural industry, and is an acknowledgment that the product meets high criteria standards and is worthy of the attention of primary producers.**



Alec Thompson, Dark Corner NSW *“This new crush is a bloody beauty!”*

## 5 Year Warranty

All National Stockyard Systems Headbails and Crushes come with a 5 year warranty provided the crush is installed on a level concrete pad and the products are used correctly.

Naturally all steel on steel moving parts will require some lubrication

Google national stockyard systems and click on the **YouTube** link to view our products in action.

# Standard features on all of our Crushes and Headbails

STANDARD FEATURES

- Front legs cannot get through or over the bail arm baffles.
- Diamond shaped yoke prevents excessive vertical head movement (thus whole body movement), minimising the need for engaging the chin bar.
- Chin bar facilitates tasks such as mouthing, ear tagging and pink eye treatment where restricted head movement is required. The over centre operation will not jam and can be released with one hand when under pressure.
- All tubular sections are high tensile Australian galvanised steel.
- Vertical open baffles. Vision of cattle is not restricted hence cattle will walk up closer to it. Makes catching easier.
- Tension bars transfer attempted outward movement at the base of the headbail back to the frame of the cattle crush. Thus, the bail arms remain absolutely parallel, even under extreme pressure.
- Note the solid 65 x 65mm bail arms (even if you only catch a few animals it only takes one rogue animal to bend lighter 50 x 50mm bail arms that other crush manufactures and importers supply).
- **Award of Excellence. Australian National Field Days 2013 for Innovation. Manufacture and Design.**



- Catch and release handles can be disengaged for safety



- Needle gate in open position. Width & depth gives outstanding access.



- Needle Gate standard on all crushes except Basic models



- Catching ease is facilitated by 3 quick lift and drop settings. These 3 settings are designed for calves and weaners, cows and steers, bullocks and bulls.



- Self cleaning Headbail & Split Side Gate base.
- Bolt down lugs fitted to base, these lift the body of the Crush to minimise rust.
- Slam catches on all gates.



- Our crushes are manufactured for functionality, longevity and strength. We pick our crushes up through the gates as we do not need special lifting points



- Chin Lifter is off set so that it lifts under the chin and not the throat or brisket. The chin lifter can be released instantly no matter what downward pressure the animal is applying to it.

Google national stockyard systems and click on the **YouTube** link to view our products in action.





- Full Vet walk through on all Vet Crushes except Hunter Basic



- Hooks to hang bags off and holders for the vaccinating gun. The poly insert in the holders will protect your needles.



- Both vet access gates lock across.



- Kick Shut vet gate. Open and close with foot.



- All sheeting has a silicon barrier between the RHS and the sheet to prevent rattle noise. Another bead of silicon prevents water and dirt being trapped in the groove.



- All stress points on the crush are plate braced for extra strength



- Leverage assisted split sliding gate. This innovative gate blocks the following animal from both sides. Often the following animal has it's head over the rump of the leader. It is much easier to baulk the head instead of trying to jam a conventional sliding gate on the shoulder. Further, if the operator can only just reach the handle, from any direction, the gate can be easily operated. Closing is auto lock and opening is auto release. Following cattle will stand closer to the gate and sheet rattle noise is eliminated. Australian Patent No. 2007792950

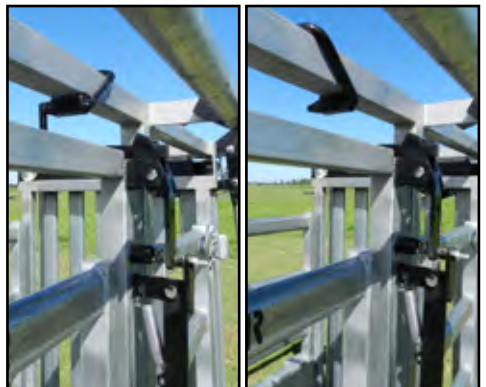

- Tumble Tommy prevents sides of squeeze crushes from vibrating in. Usually engaged if running multiple animals through for loading etc.
- Tumble Tommy disengaged to allow squeeze to be activated.

**Our standard range of inside crushes**



**National Stockyard Systems has Australia's largest range of crushes. Designed for all applications. Onside & offside operation available on all products.**



# Hunter Headmaster Headbail

**5** Year  
Warranty



Also available as a Top End Headbail  
(4mm thick RHS frame and ratchet chin lifter)

- Suitable for most applications.
- Rear catch handle is available.
- Often purchased to rejuvenate an aged crush.

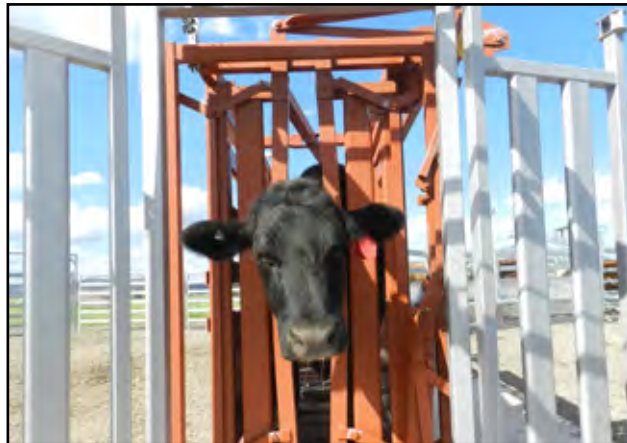

Internal width 730mm  
Maximum outside width 1100mm

# Tweed Basic Cattle Crush

**5** Year  
Warranty



Note the extra length of this crush. Most other economy crushes on the market are too short in the body to hold an animal comfortably prior to catching in addition to all the standard features on page 6 and 7

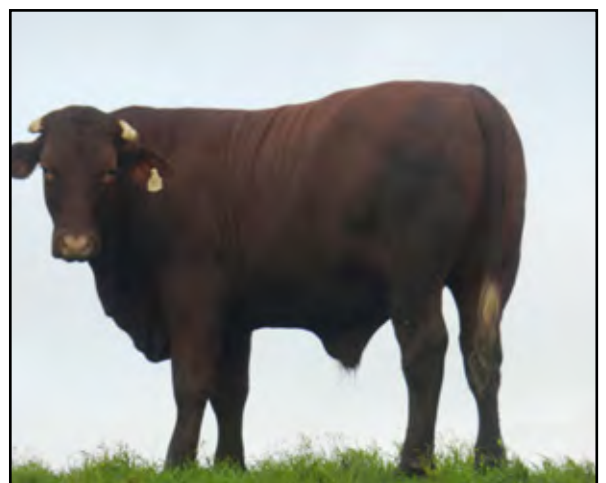

Length 2620mm  
Internal width 730mm  
Maximum outside width 1100mm  
Split gates inside solid outside

# Tweed Standard Cattle Crush

**5** Year Warranty



Length 2420mm  
Internal width 730mm  
Maximum outside width 1100mm

The Tweed standard crushes are available with single diagonal squeeze (Settler) and double diagonal squeeze (Pacifier)

Split body gates on the on side. Single body gate on the off side in addition to all the standard features on page 6 and 7



# Hunter Basic Cattle Crush

**5** Year Warranty



Length 3250mm  
Internal width 730mm  
Maximum outside width 1100mm

A no frills crush. On side allows access to the animal with the vet access and split body gates. Off side is solid in addition to all the standard features on page 6 and 7



**Terry McGovern, Manton.**

Jill and I looked at numerous suppliers for our new crush and yards, I am glad we waited until the Murrumbateman Field Days. We are thrilled with our crush and yard from NSS

Google national stockyard systems and click on the **YouTube** link to view our products in action.



# Hunter Standard Cattle Crush

**5** Year  
Warranty



Split body gates on the on side. Single body gate on the off side in addition to all the standard features on page 6 and 7



**Enquire about our range of weighing and drafting systems to speed up your through put.**

Length	3250mm
Internal width	730mm
Maximum outside width	1100mm

# Hunter Settler Cattle Crush

**5** Year  
Warranty



Single squeeze provides a simple push-pull action with automatic lock and release for altering the width of the crush. Maintains good view of, and access for, neck vaccinating and injections. Most cattle will settle better if movement is restricted. Split body gates on the on side. Single body gate on the off side in addition to all the standard features on page 6 and 7



Length	3250mm
Internal width	730mm
Maximum outside width	1100mm

Single Sided Diagonal Squeeze



Simultaneous double sided diagonal squeeze provides a simple push-pull action with automatic lock and release for altering the width of the crush. It can be activated from either side of the crush and maintains good view of, and access for, neck vaccinating and injections. Most cattle will settle better if movement is restricted. The squeeze enables calves to be marked easily while standing. For smaller operators this eliminates the need for a calf cradle, force and race. Split body gates on the on side. Single body gate on the off side in addition to all the standard features on page 6 and 7

**Our best selling crush**

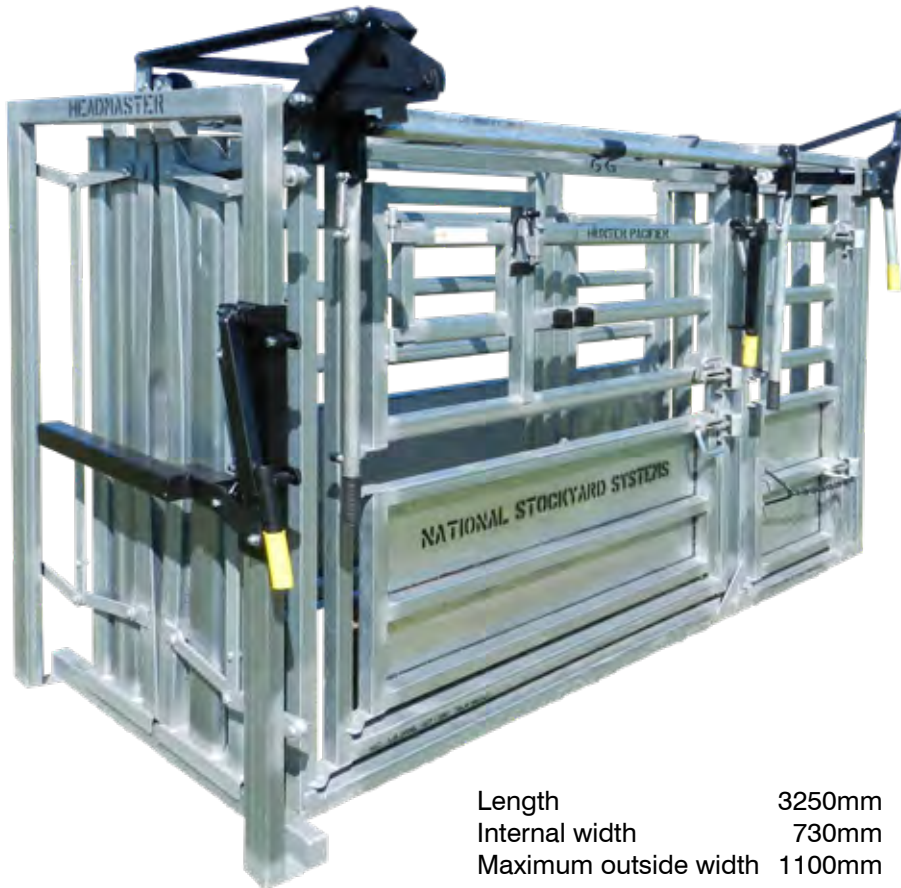

Length 3250mm  
Internal width 730mm  
Maximum outside width 1100mm



The amazing flexibility of the double squeeze Hunter Pacifier.



**Peter Wallis. Gundowring.**

In my livestock management business I use many different cattle crushes but my National Stockyard Hunter Pacifier is by far the best to use. The split slide gate, kick shut and open vet gate, the squeeze and the headbail are a pleasure to use and nothing ever pulls back out.



Double sided diagonal squeeze



We also sell a full range of Tru-Test range of Weighing and Identification Solutions for Livestock Management

Google national stockyard systems and click on the **YouTube** link to view our products in action.

# Hunter Stabiliser Cattle Crush

**5** Year  
Warranty

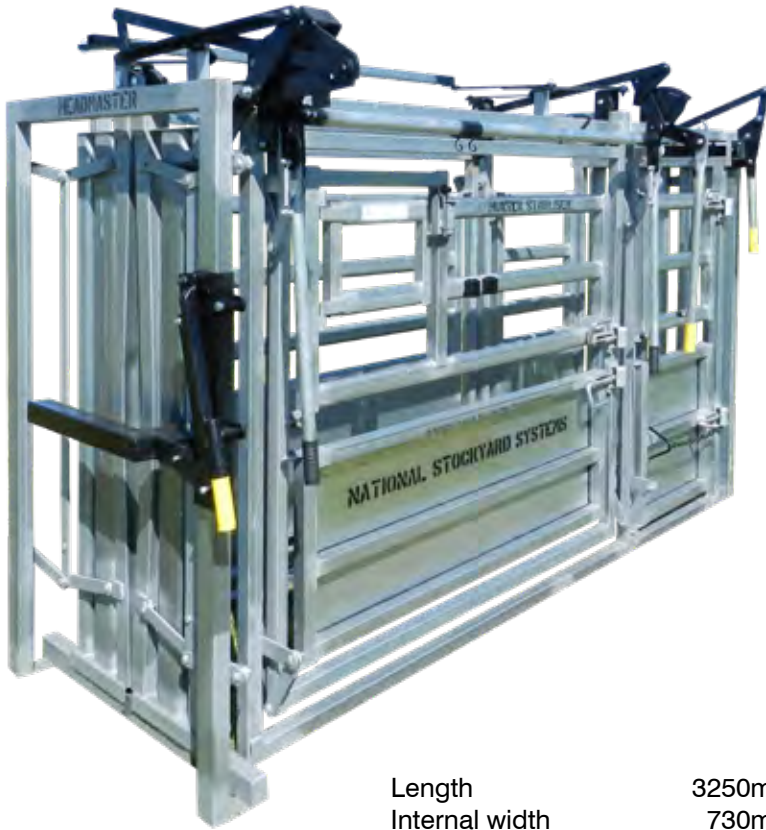

Length 3250mm  
Internal width 730mm  
Maximum outside width 1100mm

Ratchet parallel squeeze provides one handed movement for altering the width of the crush. Maintains good view of, and access for, neck vaccinating and injections. Most cattle will settle better if movement is restricted, this crush is excellent for calf marking.

Split body gates on the on side. Single body gate on the off side in addition to all the standard features on page 6 and 7



# Bullock Standard Cattle Crush

**5** Year  
Warranty



Length 3350mm  
Internal width 730mm  
Maximum outside width 1100mm

Heavy duty construction.

Split body gates both sides in addition to all the standard features on page 6 and 7



Google national stockyard systems and click on the **YouTube** link to view our products in action.

**See our range of optional extras to customise your crush.**



# Bullock Pacifier Cattle Crush

**5** Year  
Warranty

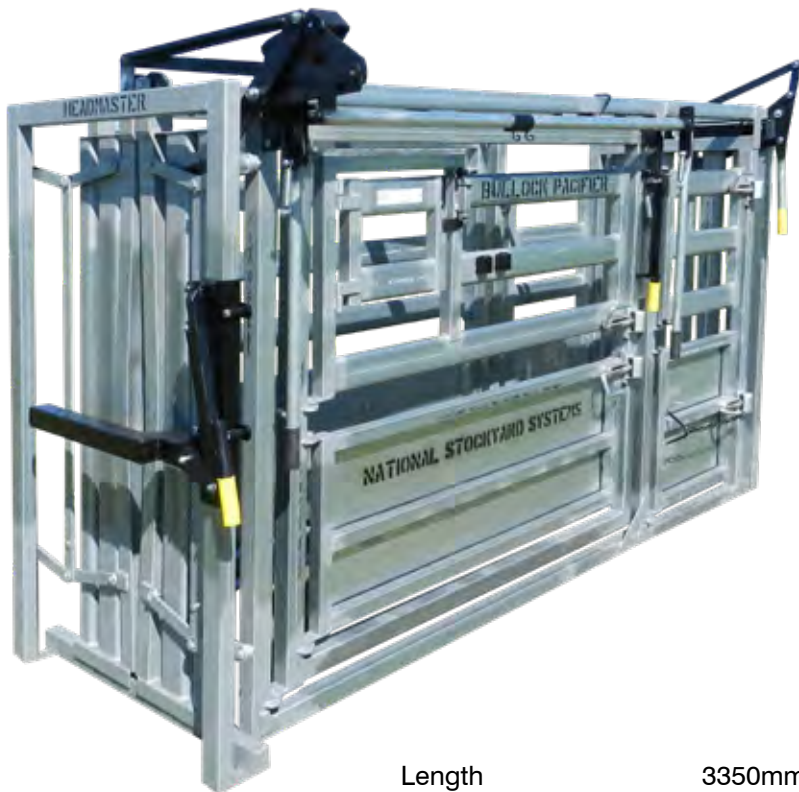

Length 3350mm  
Internal width 730mm  
Maximum outside width 1100mm

Heavy Duty construction  
Simultaneous double sided diagonal squeeze provides a simple push-pull action with automatic lock and release for altering the width of the crush. It can be activated from either side of the crush and maintains good view of, and access for, neck vaccinating and injections. Most cattle will settle better if movement is restricted. Split body gates both sides in addition to all the standard features on page 6 and 7



**Large numbers of cattle can be processed quickly with a suitable crush and yard system supplied by National Stockyard Systems**

# Top End Stabiliser Cattle Crush

**5** Year  
Warranty

Top end crushes are available with full parallel squeeze (Stabiliser) and without squeeze (Standard)



Length 3350mm  
Internal width 730mm  
Maximum outside width 1100mm

- Extremely heavy duty construction
- RHS sections are 4mm thick
- Full ratchet parallel squeeze See page 15
- Ratchet chin lifter
- Split Body gates both sides
- These are in addition to all the standard features on page 6 and 7

**Our range of Top End Crushes are designed for studs, sale yards, large operators etc.**



A Top End Standard in use at the Maitland Regional Sale yards. This crush has an annual throughput of about 20,000 head of cattle of varying temperament.





Length 3650mm  
Internal width 825mm  
Maximum outside width 1200mm

- Not just a crush, this is more of a Cattle Processing Machine
- Extremely heavy duty construction.
- RHS sections are 4mm thick
- Full ratchet parallel squeeze
- Ratchet chin lifter
- Split Body gates off side (hinged front)
- 7 access gates on side and 3 access gates off side
- Ratchet rump bar standard
- Scanning louvre gates



Runner up. Henty  
Machine of the Year  
2014



This crush weighs over a ton and is an extra 200mm longer in the body. It also has an extra 100mm internal width to accommodate larger framed stud cattle. There are 10 opening gates on the crush to access all points on an animal.



The louvre gates are opened and closed simply by rotating a handle, this allows quick access for scanning bulls and other husbandry procedures. These louvre gates are available on all of our crushes.

Google national stockyard systems  
and click on the **YouTube** link  
to view our products in action.

A National Stockyard Systems crush is the best crush you will ever own  
 We manufacture all of our products so we can optimise your crush to cater for a range of individual requirements.

	Hunter Head Bail	Top End Headbail	Tweed Basic	Tweed Standard	Tweed Settler	Tweed Pacifier	Hunter Basic	Hunter Standard	Hunter Settler	Hunter Pacifier	Hunter Stabiliser	Bullock Standard	Bullock Pacifier	Top End Stabiliser	Top End + 200 Stabiliser
<b>Standard Features</b>															
100% Made in Australia															
100% Australian Made High Tensile Galvanised Tubular Steel															
Patented Headmaster Headbail															
Patented Top End Head Bail															
Front and Rear Catch & Release															
Standard Chin Lifter															
Ratchet Chin Lifter															
Vaccination Hooks and Holders															
Sheeted Split On Side Body Gates															
Sheeted Single Off Side Body Gate															
Sheeted Split Off Side Body Gates															
Needle Gate															
Number of Crush Gates (Excluding Head Bail & Split Slide)			2	4	4	4	4	7	7	7	7	8	8	8	10
Patented Split Slide Gate Entry															
Stress Points Gusset Braced															
Complete Bruise Free Entry and Exit (730mm Internal)															
Self Cleaning Head Bail and Slide Base															
Cush Frame Lifted on top of Anchor Bolt Lugs															
Auto Catch on All Gates															
Dual Gate Vet Access (Kick operated Bottom Gate)															
Dual Vet Access Gates and Full Walk Through Vet Access															
Ratchet Rump Bar															
Semen Collection Gate															
Louvre Gate for Scanning, Cross Branding etc.															
All RHS Frame 4mm Thick															
Top End Head Bail															
Single Side Diagonal Squeeze															
Double Side Diagonal Squeeze															
Double Side Ratchet Parallel Squeeze															
Silastic Noise and Rust Minimising Barrier															
Off Side Operation Available															
<b>Optional Extras</b> Available															
Welded in Floor and Weigh Bar Mounts															
Auto Baulk Gate															
Standard 3 Stage Baulk Gate															
Ratchet Chin Lifter															
Head Scoop (On Ratchet Chin Lifter Only)															
Louvre Gate															
Ratchet Rump Bar															
Extra Body Gates (Full Length or Semen Collection etc.)															
Extra Off Side Needle Gate (Not compatible with EID Board)															
Operate Split Slide Entry with Dual Handles (1 each side)															
Tru Test Weigh System / EID Mounting Boards etc.															



# Optional extras that are available on all our Crushes

**STANDARD FEATURES**

Off side operation is available with all our products (5% pricing premium applies)



Google national stockyard systems and click on the **YouTube** link to view our products in action.



Rump Ratchet Bar (Standard on Top End stabiliser plus 200)



Full Ratchet Chin Lifter (Pictured on a Hunter Pacifier) Note how we have lifted the ratchet mechanism for the ratchet chin lifter. This is to minimise injury to animal and operator. (Standard on the Top End range but can replace the standard chin lifter on any crush or headbail).

Extra body gates can be ordered with your crush

Nearside and offside operation available



Split Slide Gate can be customised to open and close from both sides of the crush.



Floor is 3mm thick with 3mm treads all fully welded in. Weigh Bar Mount can be punched to suit Tru-Test or supplied as unpunched to suit other weigh bar suppliers.



Floor is welded in and includes weigh bar mounts. Load Cell or H-Bar mounting brackets can be fitted to all NSS Crushes.



Weighing. Large weather proof EID antenna mounting board.





**We also sell the full range of Tru-Test Weighing and Identification Solutions for Livestock Management.**

**Thus we are a one-stop shop.**



3 stage baulk gate is heavy duty construction. Cattle will not go over, under or through the baulk gate.



3 stage baulk gate open.



Auto Baulk closed. Cleverly designed linkages allow both baulk gates to open and close by pushing or pulling one gate.



Auto Baulk open. By pushing or pulling the on side, the off side will be mirrored through clever linkages. There is no better baulk gate available.



The 3 stage baulk gate is handy for catching horned cattle.



Double acting louvre rails can be fitted to any crush. (Standard on a Top End plus 200).



Louvre Gate the rails open and close with a simple rotation of the operating handle.



A Baulk gate is essential when catching horned cattle.

*Australian Design Application No. 20414004*



The full range of Tru-Test Livestock Management Systems including scales readers and indicators, weigh platforms and drafters etc.



Ratchet chin holder is an optional extra.



**Lonnie Stone. Bovine Scanning Services**

*"This crush makes our work so much easier & safer" Louvre gates standard on Top End plus 200. Available on all other crushes.*

# What to avoid - and why....

(When purchasing a cattle crush)

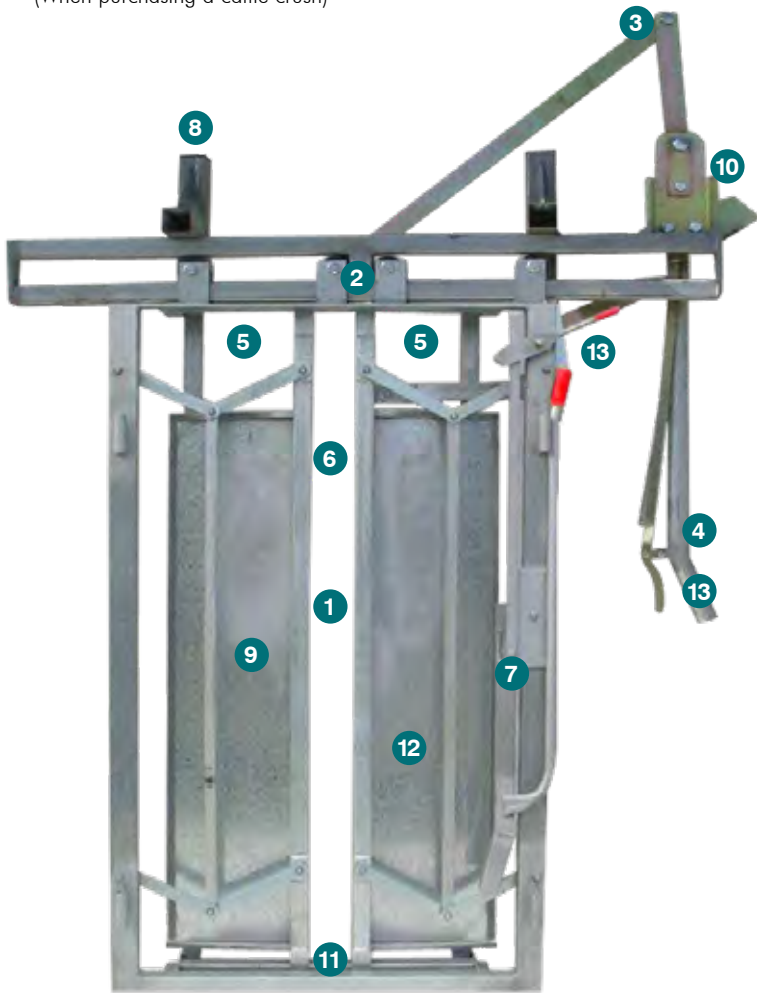

Google national stockyard systems and click on the **YouTube** link to view our products in action.

- 1 A headbail that closes in increments of 30 to 40mm. You cannot get that last click and the animal sucks back.
- 2 **Imported Headbails.** Chinese Steel is inferior to Australian Made Steel. Tell tale signs are bolted together components, odd sized steel, stitch welding, touch up paint that does not match the rest of the paint, the reluctance of the supplier to offer options such as off side, and, shortcuts in the quality.
- 3 Poorly designed linkage that does not give the operator mechanical advantage. Head husbandry is easier if the animal's neck can be held securely.
- 4 A crush or headbail that is heavy to use – gets tiresome after a few hundred head in a day.
- 5 An animal can get a front leg over the top of the baffles and then sink down. It takes a lot of effort and strength to release the animal.
- 6 Straight bail arms which allow excessive vertical head movement.
- 7 Bruise or tear points as the animal exits the crush.
- 8 Open holes allowing water to collect and rust.
- 9 Thin sheet steel that rattles excessively and rusts out as water and dirt are collected in the seams.
- 10 Bolt holes that are not sleeved. The RHS will wear quickly and elongate the hole
- 11 A design allows for build up of dirt and rocks. Hard to close a headbail if there is a rock in the way.
- 12 Excessive noise. Cattle hate noise.
- 13 A Headbail or chin lifter that cannot be released under pressure. It can only take a few seconds to choke an animal



**In addition to the Headbail the following points apply to a poorly designed crush and is there any warranty offered?**

1. Crush bodies that are too short for an animal to stand in comfortably prior to catching – a big problem with many non vet access crushes on the market.
2. Rail gaps in the crush body that will facilitate broken legs or operator injury. Even if a body gate is sheeted a large gap between the gate and the base frame has resulted in many animals breaking their shins.
3. Rail gap spaces on the entry sliding gate that allow for an animal to get it's head stuck.

4. 2 way slam catches. If a beast kicks the gate you can be hurt.
5. **Imported Crushes.** Chinese Steel is inferior to Australian Made Steel. Tell tale signs are bolted together crushes, odd sized steel, stitch welding, touch up paint that does not match the rest of the paint, the reluctance of the supplier to offer options such as off side operation or extra gates, and, shortcuts in the quality. You maybe told by an importer that their crushes bolt together to transport flat packed but they leave out the words **("in a container")**
6. Excessive noise. Cattle hate noise.
7. Many vet crushes on the market are too short for efficient Preg testing, Artificial Insemination, Scrotal measurements & Palpation & Udder inspections etc (some vet crushes sold are up to 500mm shorter in total length than our vet crushes)
8. Is the crush too narrow for today's modern cattle?

© Copyright - National Stockyard Systems  
Copying of this work in whole or in part may not be carried out without the express written permission of the Copyright Proprietor.



# Loading Ramps

All National Stockyard Systems loading ramps are fully galvanised and feature a **patented concrete floor** (except budget) with plenty of treads. Timber floors are subject to rot, white ant attack and fire. Steel floors are prone to noise and rust.

All ramps have a closed in base to prevent legs getting outside of the ramp. Overhead bracing is standard on both ends of the ramp to prevent side spread.

Note: The bumper board at the front of the ramp is adjustable to cater for different height trucks. Flat load out platforms with truck access gate also available.

Platform standard lengths are 1.0 Metres and 2.1 Metres.

All loading ramps (including budget) now come with sleeves and concretable spigots to prevent the ramp being shunted by trucks

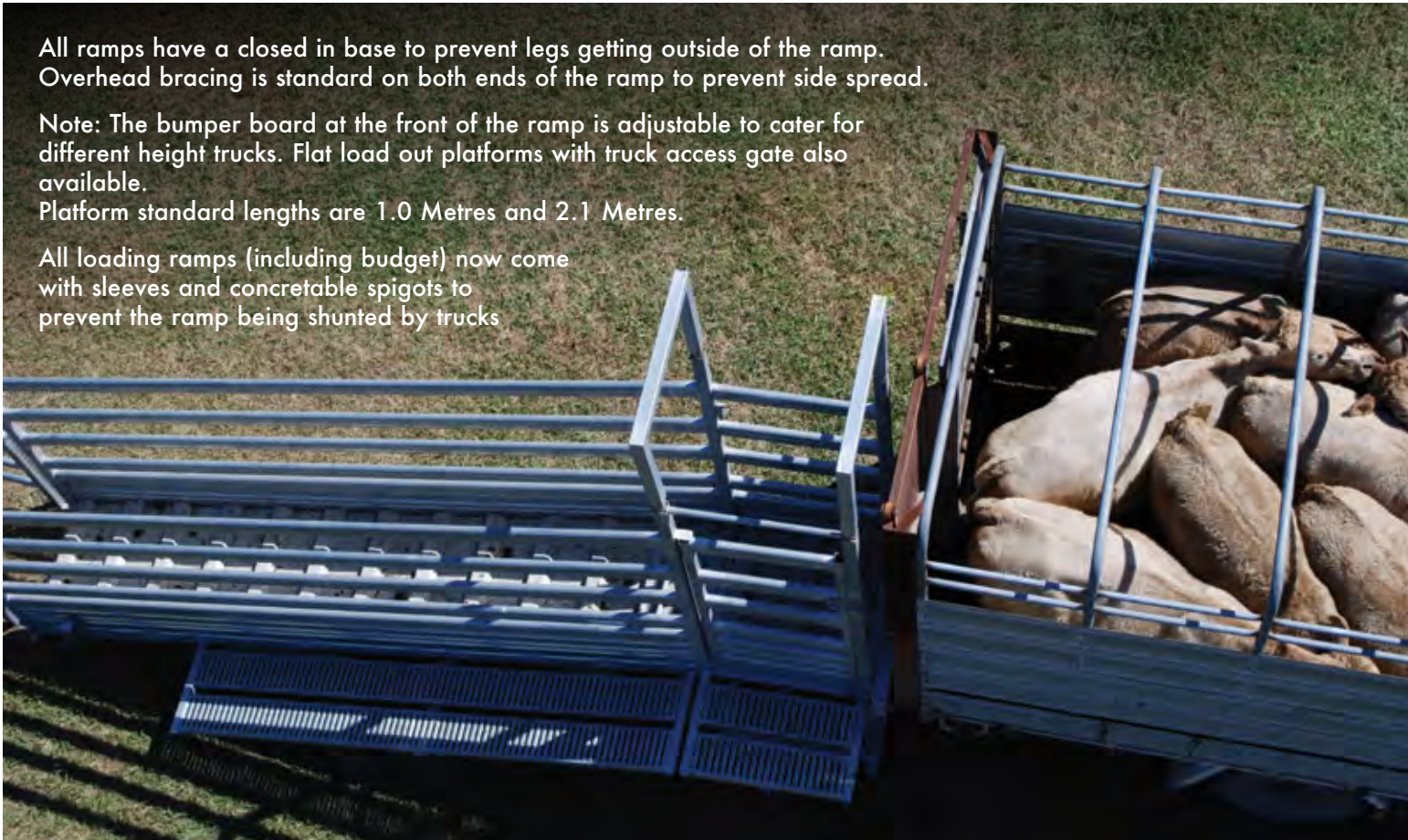

We manufacture a complete range of loading ramps to suit all requirements. Pictured 3.6 Metre ramp and side load platform





# Loading Ramps (Hunter)

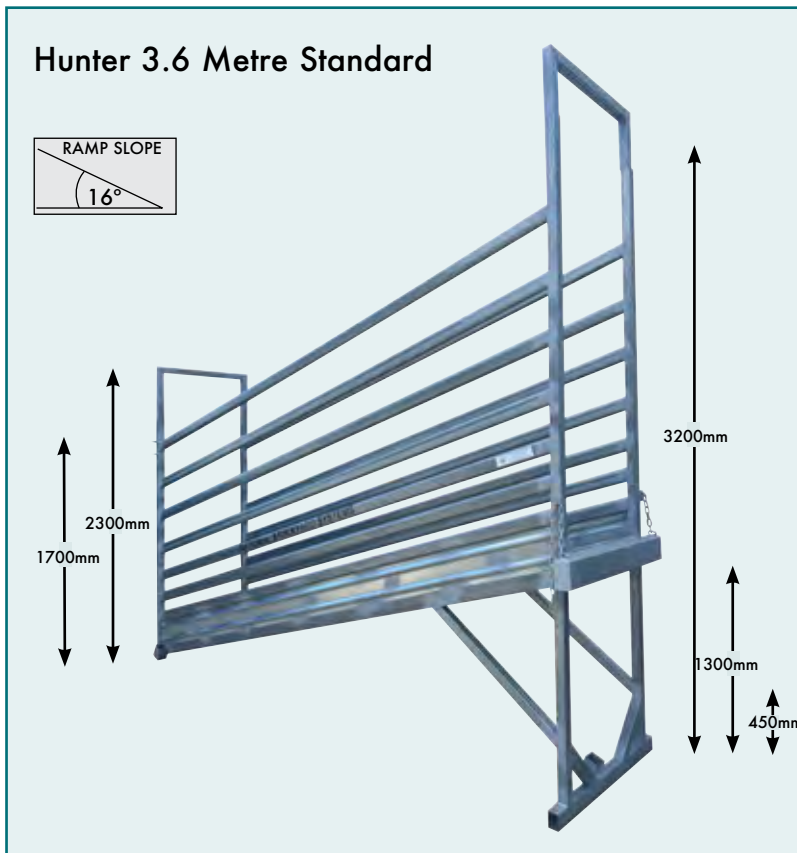

**Barry O'Neil, Dungog**

*"I have bought different yards over the years on behalf of people that I manage places for but these yards are the cheapest by far and the best by far"*



**Jim Lyons, Nemingah**

*"The yards are really well designed and cattle will pour through them"*



# Loading Ramps (Bullock)

## Bullock 3.6 Metre Adjustable Height

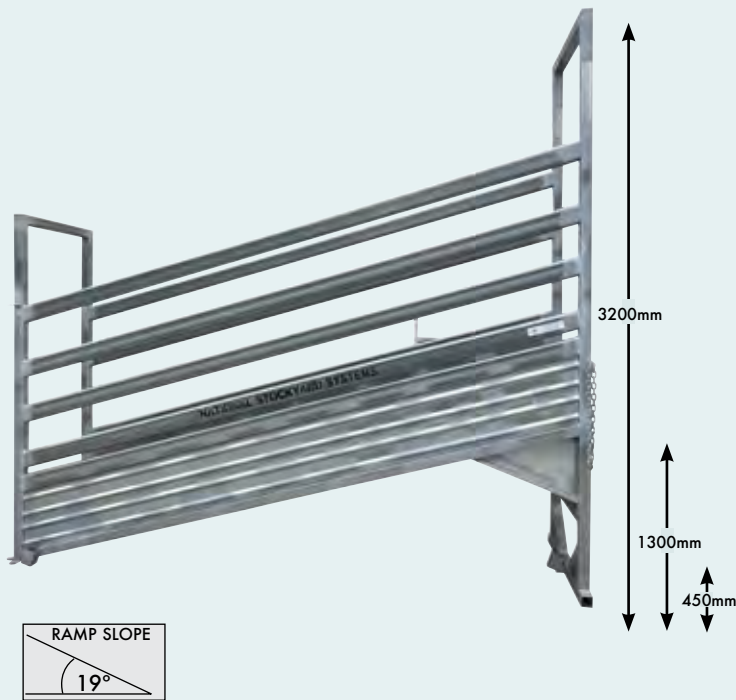

Pictured with height around 800mm for back of Ute. Ramp is easily adjustable from 450mm to 1300mm. The ramp is available as standard, adjustable, with walkway or any combination. **(Note: all ramps now come with sleeves and spigots)**. This is probably our most popular ramp.

The height is quickly adjustable by lifting the floor and sliding the chain, a child could adjust the height of this loading ramp 25 in one inch increments from box trailer height, ute body height to semi trailer height.

Ramps can go off the side (pictured), off the front of the race or load out yards.

The rail sizes of our Hunter Ramps are 75 x 40mm, and 115 x 42mm on the Bullock Ramps. All fixed height ramps are supplied with a floating height 125 x 75 x 3.0mm heavy duty bumper board.



All NSS ramps have at least 3 sleeves and spigots. After the ramp is set in position a hole is dug under each sleeve, the spigots are dropped into the holes and the holes filled with concrete. This prevents trucks from shunting the ramps.



## Loading Ramps (Bullock)

Bullock 4.2 Metre Ramp with Walkway & 1.0m front extension.  
The access gate swings across to block the ramp.

All ramps are available as standard, adjustable, with walkway or any combination.



Bullock 3.6 Metre with Walkway





# Loading Ramps Concrete Floor

- INDIVIDUAL PADS ARE 800mm LONG
- NO BAULKING NOISE
- WILL NOT RUST
- TREADS EVERY 200mm
- LESS SLIP
- STRONGER AND LAST LONGER THAN TIMBER
- MODULES AVAILABLE FOR SALE
- **Compression tested** – Elastic at 3 tonne – Fracture at 3.6 tonne

**AUSTRALIAN PATENT 2006100701**



**Pictured a Bullock 3.6m Ramp with Front Platform.**



- 1 Concretable drop in posts to prevent movement (standard on all ramps).
- 2 Adjustable height front bumper.
- 3 Sheeted sides.
- 4 Closed in rails to prevent heads going through.
- 5 Gate can block off more cattle coming up ramp if operator going into the truck to pen up.
- 6 Gate can close off truck door to prevent cattle coming back whilst operator penning up truck.
- 7 Rails behind truck block off gate prevent cattle going over side of ramp if truck block off gate accidentally left in wrong position.
- 8 Concrete floor
- 9 Walkway with handrail.
- 10 High overhead bracing

**\*Concrete floor standard on all ramps!** (except budget)

\*Except adjustable height section

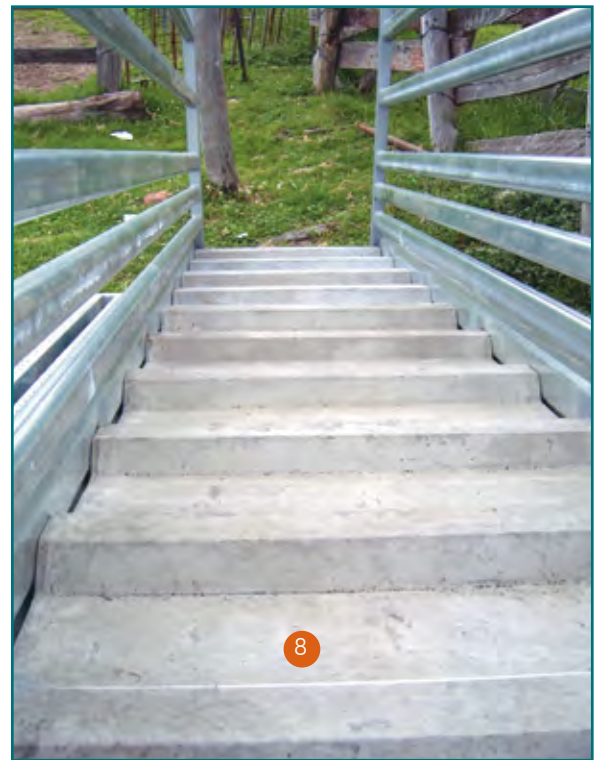

Pictured a Bullock 5.0m Ramp with truck access door and walkway.



**Ken & Libby Burkinshaw, Lockhart**

*"We needed 2 sets of yards. I did my homework very carefully before deciding on National Stockyard Systems. The rail spacing allows us to work sheep in the yards as well and even sheep pour up our ramp".*



# Yard Design



- 1 Lead up yards have rounded outside to encourage stock flow. No working yard corner is under 90 degrees.
- 2 Manways are wide enough to prevent an animal being caught by the hips if accidentally left open or they can be used to file stock through if required. These are standard on most plans.
- 3 Race entrance has off side in line with the race. This prevents two animals jamming and then both turning back. Generally the outside animal will go forward.
- 4 Good operator access around headbail.
- 5 Gates fold right back 180° behind stock and through 100°.
- 6 Yards get smaller as stock approach race. Shorter panels are used in pressure areas.
- 7 The longer panels in holding yards balance the yards and offer better value for money.
- 8 Wide entrance gates are standard on larger yards.
- 9 Two way draft out of the crush.
- 10 An often repeated comment from clients is the yards are bigger than they look on paper.

*Outside yards can be enlarged easily. An extra 2 or 3 panels makes a big difference in holding capacity.*

## NSS80-3PCR (5)

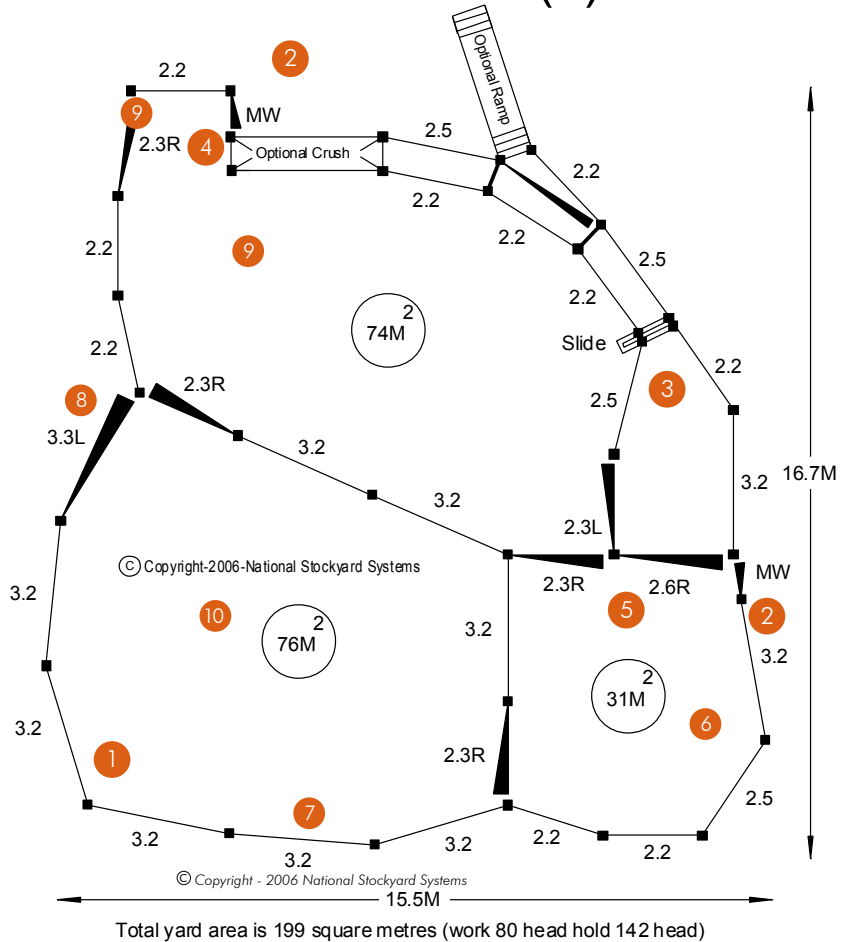

The gate folds right back 180° behind stock flow. This prevents stock, especially calves getting caught behind the gate. The gate can then be swung shut from any position.



The gate will still go through over 100° in case stock needed to be brought back against the normal stock flow direction.





Realistic yard working capacities are quoted. Generally capacities and total holding numbers are based on area requirements to handle and work 400kg cattle.

Cows and calves will require double this area.

A circular yard with the same perimeter has a greater surface area than a square or rectangle yard (and stock flow better).

## AREA REQUIREMENTS FOR WORKING YARDS

	Holding Yards	Forcing Yards
100 – 300 kg	1.3m <sup>2</sup>	0.6m <sup>2</sup>
300 – 500 kg	1.4m <sup>2</sup>	1.0m <sup>2</sup>
Over 500 kg	1.6m <sup>2</sup>	1.2m <sup>2</sup>
Cows & Calves	2.2m <sup>2</sup>	2.2m <sup>2</sup>

- Holding capacities quoted on our plans are based on 400 kg dry cattle
- Cows and calves should never be tightly forced or in the race together



The central pound allows for one person drafting and transfer of stock through the yards.

When utilising the pound for drafting the slam pin is rolled back so the pin does not protrude. The stop prevents the gates having to be latched every time an animal is drafted. One person can draft 4 separate ways with a 6 sided pound (5 gates, 1 panel) and 7 separate ways with an 8 sided pound.



Google national stockyard systems and click on the **YouTube** link to view our products in action.

A 6-sided pound of 2.6 Metre gates has a diameter of 5.2 Metres. This is comfortable for one person drafting. A 7-sided pound has a diameter of 5.4 Metres utilising 2.3 Metre gates, and 6.2 Metres utilising 2.6 Metre gates. An 8-sided pound has a 6 Metre diameter utilising 2.3 Metre gates. 9 sided pounds are available.

# What to avoid - and why...

- **Narrow yard entrance gates**
- **Lack of manways**
- **Lack of cross-over gates**
- **Hidden extra costs Re: ground pins etc.**
- **Exaggerated claims with regard to holding/working capacities.**  
(some capacities claimed must relate to drought stricken weaners or goats).
- **Gates that hinge on the outside periMetre of the yards**



Gates hinged on outside of the yards result in poor stock flow and unnecessary walking for the operator



Bent gate frame. Our centre joining lug prevents this from happening



Bad corners in yards which have to be blocked off, caused in part by the gate hinging the wrong way (because the gate will only swing 90 degrees)



Bruise or cut points as stock pass. Under pressure this gate frame will bend and render the slam catch useless. Also gate can fly straight past the keeper.



This is as far as the gate will open. This results in gates broken off their hinges due to the massive fulcrum effect if a beast hits or backs into a gate



Slam catch pin does not rollback. Also easily opened by a tail bone, horn or nose due to no protective plate



This gate only opens around 100 degrees both ways



Cattle will not load easily up the ramp due to the V shaped force



A common hinging and latching system. The double acting hinge which allows the gate to swing 360 degrees can suck back and leave a big gap between the post and the gate



A drop bolt catch can be a rib catcher and is slow to latch



Note the gap between the panels or gates (is easy to break a leg if a leg comes down between panels). And these pins will rattle



# Comparing apples with apples ???

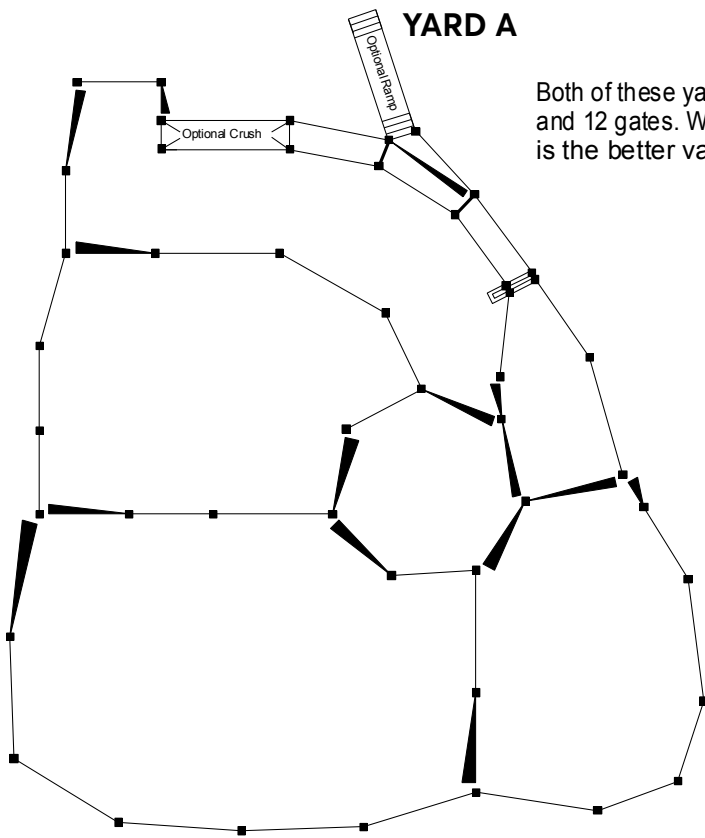

Both of these yards have 32 panels and 12 gates. Which yard is the better value????

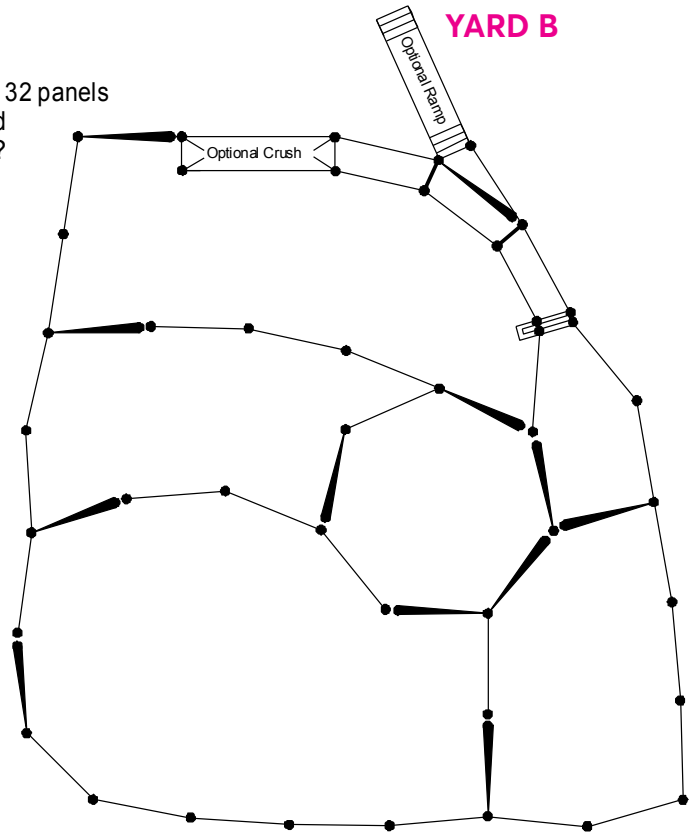

## NSS100-3PCR YARD A

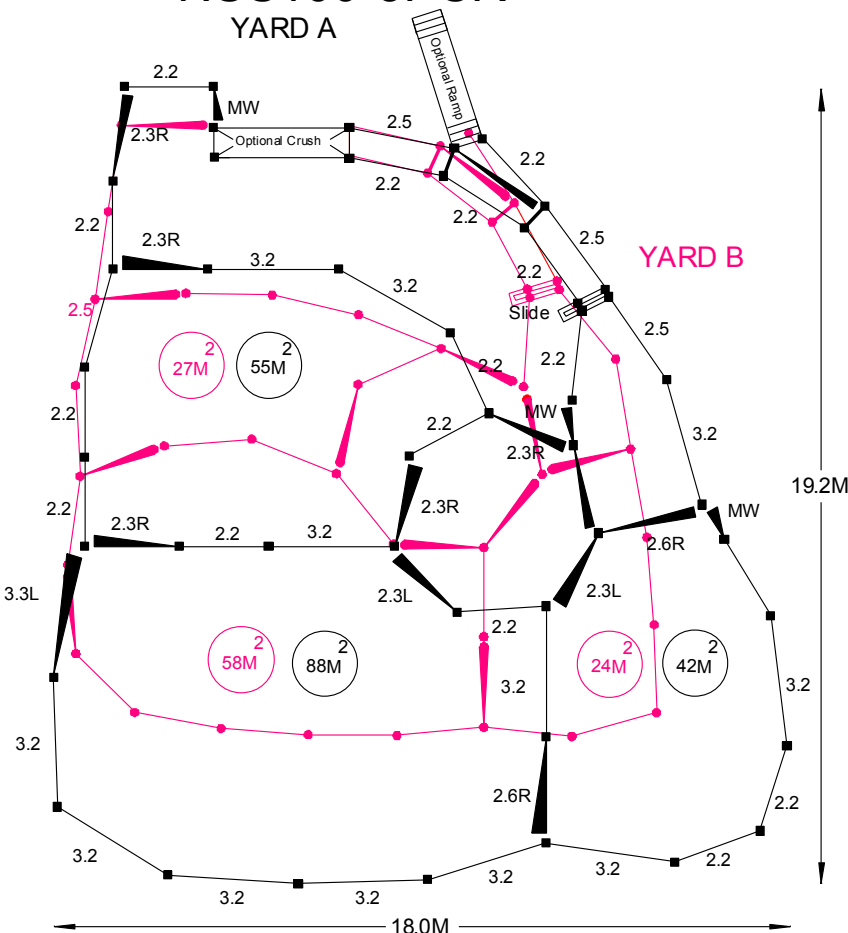

Total yard area is 261 square metres (work 100 head hold 186 head)

**YARD B** superimposed on **YARD A** exactly to scale.

**YARD B.** Total yard area is ONLY 180 square Metres (work 65 head hold 128 head).

But other suppliers may call this a 130 to 150 head yard.

**YARD B** superimposed on an **NSS YARD A** (To Scale) NSS yard is 45% bigger !!!!

NSS Gates are wider. All gates under 3.3M have the Fail Safe Slam Catch NSS Gates fold back 180 degrees and 100 degrees through. Most imported gates only 90 degrees each way and that is why some other suppliers hinge gates at the wrong end.

NSS pound gates all face the same way for efficient drafting.

NSS has a patented bolt together joining system.

NSS pricing includes all required ground pins. (Check if ground pins are included with other suppliers).

There are no manways in the imported yard.

**YARD B** uses 1.8M panels in the working race so race is shorter.

High Tensile Australian Steel is stronger than Imported Steel

# The Panel Styles

## GP (General Purpose)

Economical panel for the smaller operator. The rail is stronger than it looks.

A common yard consists of Hunter 7 rails in the race, Hunter 6 in the force and pound and GP Hybrid 6 rail in the balance of the yards.



## PANEL RAIL AND POST DIMENSIONS

	GP	HUNTER	BULLOCK 1800
Rail Number (Height mm)	5 (1600) 6 (1700)	6 (1700)	6 (1800)
Post Size	40 x 40mm	50 x 50mm	50 x 50mm
Rail Size	53 x 35mm	75 x 40mm	115 x 42mm
	GP HYBRID	HUNTER HYBRID	BULLOCK HYBRID
Rail Number (Height mm)	6 (1700)	6 (1700)	6 (1700)
Post Size	40 x 40mm	50 x 50mm	50 x 50mm
Rail Size	5 @ 53 x 35mm 1 @ 75 x 40mm	5 @ 75 x 40mm 1 @ 97 x 42mm	5 @ 97 x 42mm 1 @ 115 x 42mm

**GAP BETWEEN RAILS**

Standard Pane Lengths: 2.2M, 2.5M, 3.2M, 4.0M (Other custom lengths and heights available)  
 Standard gate in frame outside lengths: 2.3M, 2.6M, 3.3M, 4.1M, 5.2M Double  
 All panel styles are also available in 7 and 8 rail for other applications such as sheep/goat/cattle combination yards

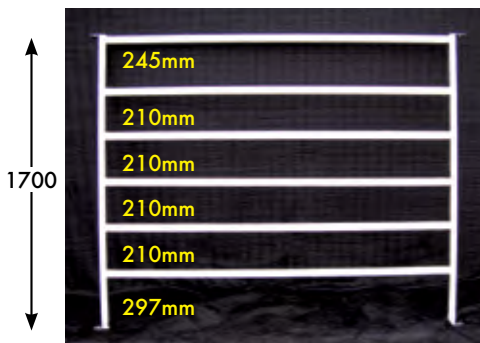

GP 6 - Rail Panel 2.2m

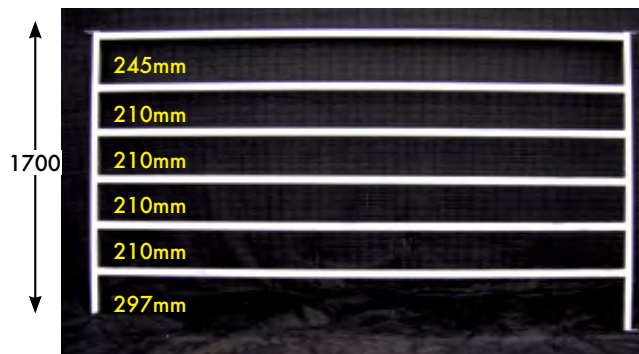

GP 6 - Rail Panel 3.2m

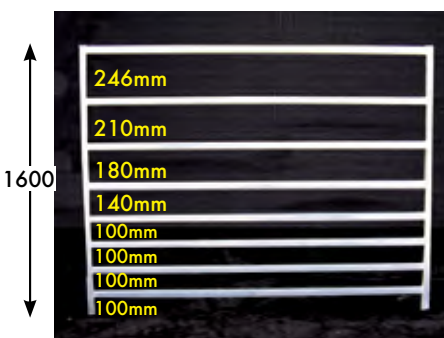

GP Combination 7 & 8 - Rail Panels available

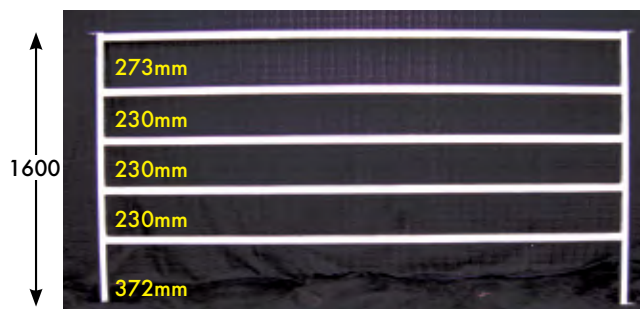

GP 5 - Rail Panel 3.2m (also available in 4 Rail for horses)

This line is exactly 210mm long. (Check it with your ruler)

This line is exactly 147mm long. (Check it with your ruler)

**Yards can consist of mixed or matched panel styles to cater for every application and budget**



### Hunter

Our most popular seller. Suited to all but extreme pressure. Hunter and all other panels have standard lengths of 2.2, 2.5, 3.2, 4.0 Metres. With a Hunter yard we generally supply a Hunter 7 rail race to prevent calves and weaners getting their heads between the rails.

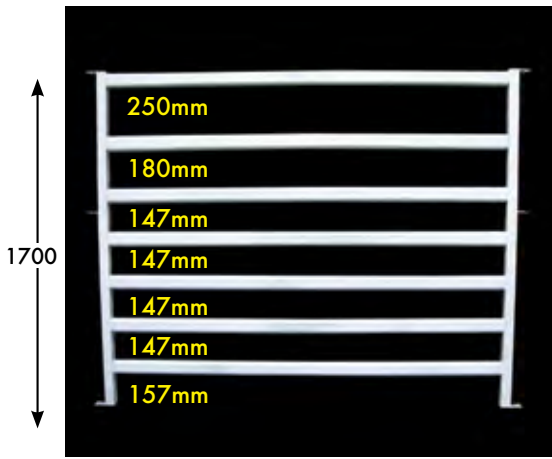

Hunter 7 - Rail Panel 2.2m

7 rails in GP or Hunter prevent calves and weaners getting their head between the rails.

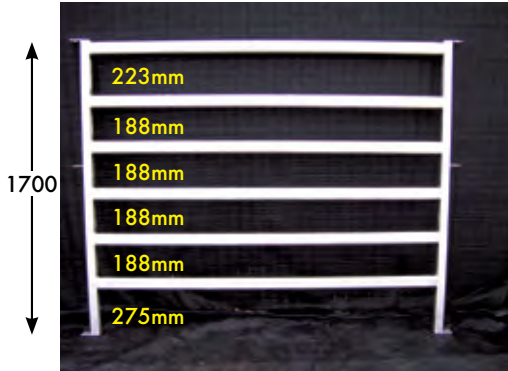

Hunter 6 - Rail Panel 2.2m



Bullock Hybrid 6 Rail. Top Rail 115 x 42 x 2mm Bottom 5 Rails 97 x 42 x 2mm is a stronger and better panel than 5 rails of 115 x 42 at the same price

### NEW Hybrid Panels

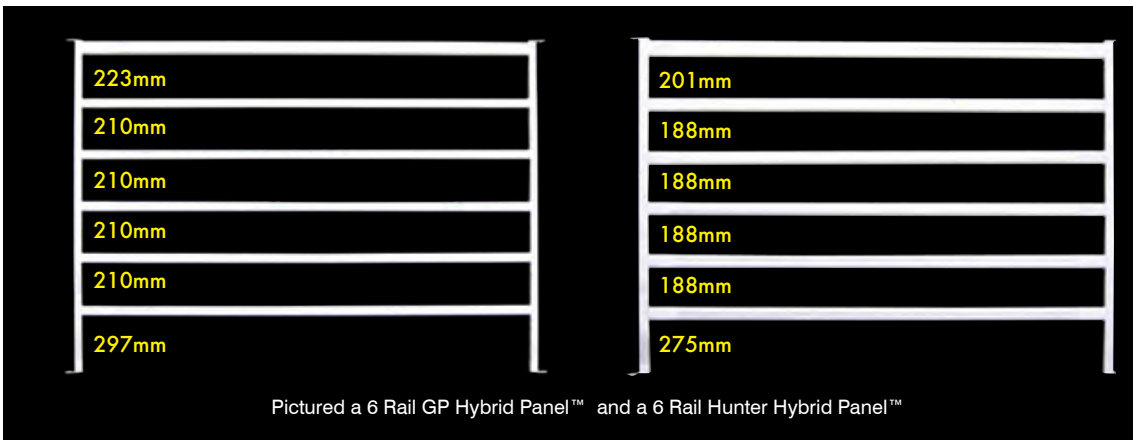

Pictured a 6 Rail GP Hybrid Panel™ and a 6 Rail Hunter Hybrid Panel™

If a rail in a stockyard is bent it is usually the top rail. We now offer panel and yards with a heavier top rail, these are our Hybrid Yards.

The 53 x 35mm top rail in GP yards can be replaced with a 75 x 40mm rail. This rail weighs 28% more than GP rail thus will be 28% stronger. The 75 x 40mm top rail in Hunter Hybrid Yards can be replaced with a 97 x 40mm x 2mm rail. This rail weighs 56% more and will be 56% stronger.

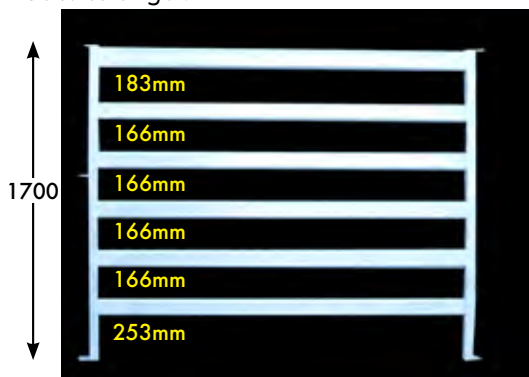

Bullock Hybrid 6 Rail Panel 2.2m

### Bullock Hybrid 6 Rail

Cap rail 115 x 2.0mm  
Other rails 97 x 40 x 2.0mm

This is a better option than the conventional panel supplied by other suppliers.

The steel costs the same as a 5 rail 115mm rail panel and there is the same amount of welding but this is a much better panel. The panel is stronger and adult cattle cannot get their head between the rails.

### GAP BETWEEN RAILS

This line is exactly 188mm long. (Check it with your ruler)

This line is exactly 166mm long. (Check it with your ruler)

## Bullock 6 1800

Suited for all applications. The Bullock 6 is the heaviest stock item manufactured and, at 1800mm high with 6 rails cattle will not get their head through it. It is popular with producers handling stock of questionable temperament.

We also manufacture a Bullock Hybrid 6 rail panel which is a better and stronger panel than the traditional conventional 5 rail panel.



Bullock Hybrid 6 Rail is Top Rail 115 x 42 x 2mm Bottom 5 Rails 97 x 42 x 2mm is a stronger and better panel than 5 rails of 115 x 42 conventional 5 rail panel.



8 Rail combination panels

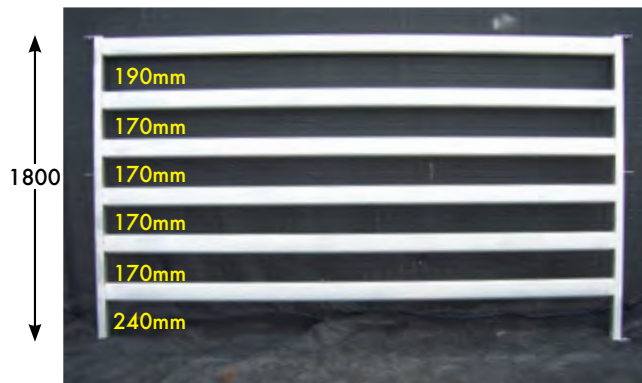

Bullock 6 - Rail Panel 3.2m

**GAP BETWEEN RAILS**

This line is exactly 170mm long. (Check it with your ruler)

This line is exactly 190mm long. (Check it with your ruler)

## Shane and Andy Murphy, Mungindi

"We needed a strong set of yards due to the agistment cattle we seasonally take on and we also needed yards we could load sheep out of. After 2 days at Ag-Quip we selected National Stockyard Systems as the best yards for our requirements."



## Concrete Stamping

The best finish is to stamp your concrete with a heavy piece of 4" or 6" pipe, or an empty paint tin upside down. This limits cattle slipping.



# The Joining System

Best of both worlds:- “the environment of permanent yards with the flexibility and price of relocatable yards”



- The joining system utilises elongated hole cleats, which mean that the panels will follow most ground undulations.
- Bolts are M12-30 hot dip galvanised with a wide flat head. Washers are hot dipped 32mm wide and nuts are standard hot dipped.
- **This system is protected by Australian Registered Design No 14534/2005 and totally eliminates the noise associated with conventional pinning systems.**
- Whilst eliminating panel rattle noise, gate sag etc the joining system will offer a degree of movement if a beast hits a panel hard.
- It only takes about an extra 10% time to build the NSS yards compared to others. (Dropping a pin in or putting a nut and washer on the bolt is the quickest and easiest part of yard erection).
- Delivery and erection is a service available to clients if required.
- The need for cost-adding false joining posts that others require is eliminated.
- There is no gap at the top of the panels for an animal (particularly horses) to get a leg caught in.
- **Note: The third middle lug on Hunter and Bullock Panels. This transfers impact on the gate to the associated panel posts which means that the gate frame cannot bow and the slam catch pop under pressure.**



Wilson Co on behalf of William and Tony Chau Ulan

*“The yards were easily the best I saw at the field days and the gates and bolt together joining system made my decision easy”.*



Doug Clark, Black Hill

*“Our yards are great and still as good as the day we bought them 4 years ago. We love the gates and the lack of noise”.*

# The Gate

The gate system and joining system are protected by Australian Patent No. 2009100939. This revolutionary gate and joining system was also awarded the Encouragement Award at the prestigious "The Land & NSW Farmers Association Farm Inventor Of The Year Competition" at Ag Quip 2005.

*The system is exclusive to National Stockyards Systems.*



- 1 Mitre cut and welded for strength (not straight cut or bent).
- 2 Gusset braced to maintain frame square.
- 3 Auto stop on top of gate, combined with bottom stop prevents gate twisting after repeated slamming.
- 4 Ground pin cleats standard. Ground pins included with all pricing for gates, manways, slides & bows.
- 5 Gate swings back 180 degrees to follow cattle flow and generally rests beside a panel to prevent stock being stuck behind it or breaking gate off its hinges. Also a 2.5 metre gate can be closed while standing up to 5 Metres from the latch.
- 6 Fail safe stop prevents gate flying past slam catch.
- 7 Gate will swing over 100 degrees through if cattle flow direction is required to be reversed.
- 8 This is simply achieved by lifting the gate. Solid continuous gudgeon allows for vertical movement to override the fail safe slam catch if required.
- 9 Slam catch is standard on all gates under 3.3 Metres on all yards from GP 5 Rail to Bullock 6 Rail. Even small yards for small numbers should facilitate easy, low stress and enjoyable stock handling.
- 10 Not just a generic gate. Note the left hand or right hand closing of the gates. This tailors each gate to cattle flow requirements. (Pictured is a right hand closing gate).
- 11 Most gates close on the outside of the yard. As the gate can be swung and latched from any position this means you are closer to the centre of the yards which mean less walking.

**Slam catches standard on all gates under 3.3 metres including manways.**





Double Gate Entry. Both gates will fold back 180 degrees and go through 100 degrees. (Gate cross-over latches also available).



Two chains and catches are supplied with all double gates. Both gates can be chained back against the panel



Combination yards are available.

## The Pegging Down



Ground pins are supplied with all NSS yards. Two pins are supplied with all gates, manways, bows and sliding gates. The 400mm Y16mm deformed bar pegs are driven through the standard pin lugs. If yards are **not** pegged down the yards **will** move and distort under normal pressure. If the panels are also required to be pegged, then a peg down plate and ground pin can be purchased which are installed as the panels are joined.



**Dave Power, Gundagai**

*"I bought the headbail because I thought it represented real value and after using it I reckon it is one of the best around. I recommend pinning the yards down. The GP yards I bought are standing up well to my Western bred cattle."*



# The Slam Catch

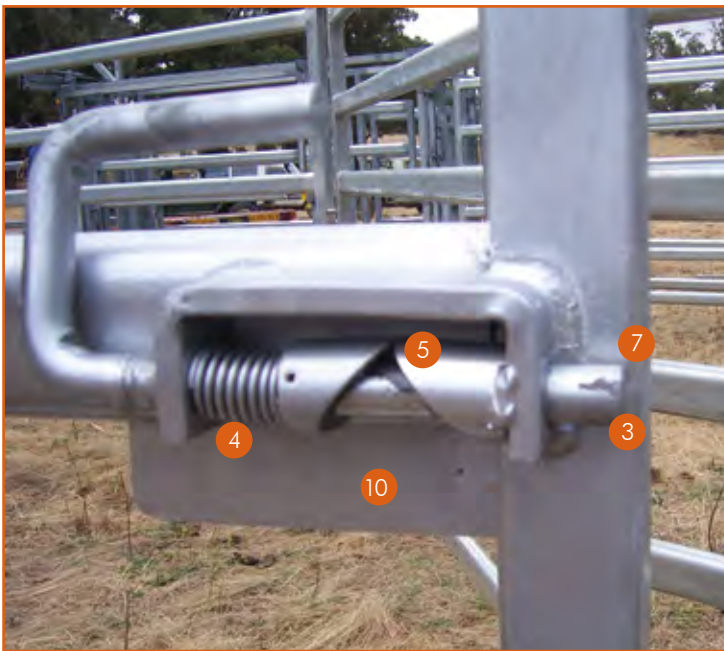

- 1 20mm Bright Bar shoot pins (not round bar) Smother action, tighter tolerances and greatly enhanced zinc coating adhesion.
- 2 Hollow Bar Cams (not pipe) Grade 750 – high tensile and very hard wearing – guarantees cam matches shoot bar with no seam.
- 3 Linished leading edges results in easier closing and prevents a narrow groove developing on the catch which binds up action.
- 4 Stainless Steel Cam Latch Spring give consistent longer lasting pressure than conventional springs.
- 5 All latch components are individually zinc plated prior to assembly with a 5-micron coating to ensure long-term rust prevention and ease of operation.
- 6 Body is 32 x 10mm flat for strength.
- 7 Note when the latch handle is rotated the pin withdraws behind the gate edge. This position is maintained automatically until the latch is re-engaged by the operator – brilliant for drafting (especially in the pound yard) in association with the NSS Sure Stop and eliminates a potential point of injury to both animal and operator.
- 8 The catch allows for up the 70mm vertical movement in gate location and closing positions and with normal corner location, shape is non-bruise.
- 9 Note how the centre-joining lug transfers impact on the gate frame to the connected panel/s or gate post/s. This triples gate frame strength and virtually eliminates the chance of the gate frame bowing under pressure.
- 10 Protector plate prevents accidental opening of catch by stock in adjacent yard.

## Alan Croll, Barraba

*"I think I was one of the first to order a set even though I was a bit sceptical about how good they'd be ... but ... they are absolutely brilliant and Angie loves the gates".*



# Calf Marking

- Larger producers, where throughput put is paramount may require a separate calf race and force.
- Swing gates with slam catches are preferential to slide gates, especially at the front of the race where it will open against the cradle.
- The calf race is adjustable width to a maximum of 450mm and the width can be quickly adjusted to suit individual requirements. (400mm or 16" is the traditional standard). Gaps between the rails are a maximum of 140mm to prevent calves getting their heads between the rails.
- Many producers are utilising a squeeze crush and mark calves standing up. This practice is very effective as it is a one-person operation and only requires a small increase in skill to mark a calf standing up utilising a National Stockyard Systems squeeze crush.

The traditional calf marking cradle has many disadvantages. The main one is that, unlike a cattle crush, it is impossible to design a cradle to cater for all sizes of calves. Another disadvantage is that the calf marking is often the first association that a calf has with humans. Utilising a traditional calf cradle where the calf is thrown off its feet, squashed, marked and then let go will leave a lasting bad experience.

National Stockyard Systems has designed a crush specifically for processing and marking calves.

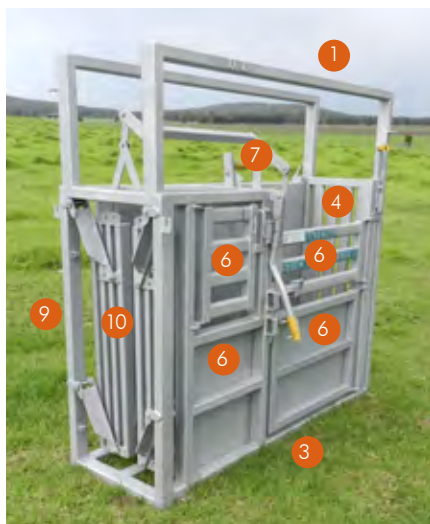

1. Extremely heavy duty construction
2. Caters for all sizes of calves
3. On Side and Off Side operation available
4. Simple Push – Pull entry gate
5. Swing – Anti Back gate in the race allows one calf entry into the crush
6. Multiple access gates for needling, ring application or cutting.
7. Ratchet immobiliser bar for branding
8. Brisket Bar prevents calves from laying down
9. Bulk Gate available.
10. Incremental closing positions

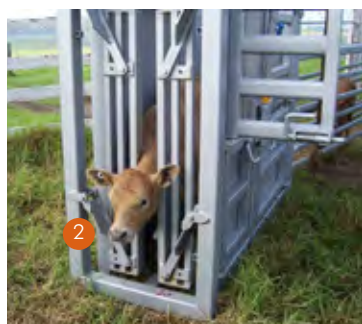

Little calves.



Big calves.



Calf race and calf force. Concertina gate folds around to make the calf force yard.



Prototype testing the calf crush, marking neighbour's calves. We refined and improved the calf crush after this. Pictured. Our neighbour, John Lidbury was more than happy to pass on some of his more than 50 years of cow and calf experience to our crush manufacturing manager, Adrian Gunthrie.

Calf crush and race with Swing - Anti Back. One calf entry. Near Side race is 1400mm high. Rail gap 147mm. Also available in Bullock Hybrid on the off side.

# Other Components



GP Slide Gate



Hunter Slide Gate

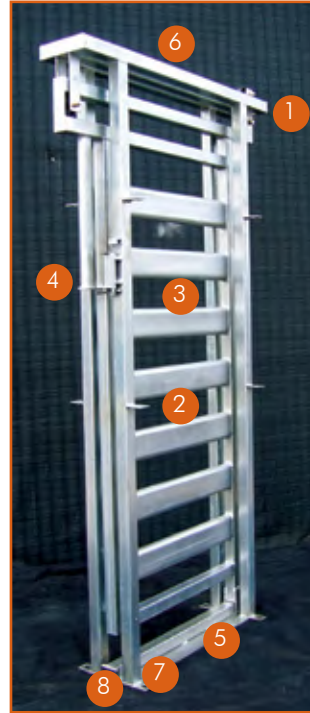

Bullock Slide Gate



Split Slide Gate (Closed)

- 1 All slide gates operate on rollers, note the extra rails.
- 2 The gap between the rails is GP 169mm, Hunter 147mm, Bullock 107mm.
- 3 These gaps minimise the opportunity for cattle to get their head through.
- 4 All sliding gates have a self locking latch.
- 5 Flat bar base on Hunter and Bullock for longevity.
- 6 Height is 1995mm (GP) 2200mm (Hunter & Bullock).
- 7 Self cleaning base.
- 8 Peg down lugs standard.



How wide is the pad big cattle leave?



Split Slide Gate (Open)

The spit slide gate is leverage assisted with auto lock this gate is around 3 times faster to operate. The far side closing will block the head of the following beast. Can be supplied with an operating handle on both sides.





**Manways** are wide enough to prevent an animal getting caught by the hips if the gate is accidentally left open, or they can be used to file stock through if required. Slam catch is standard on Hunter and Bullock and they are included in most plans, thus are not a hidden extra. An extra slide is also standard on all 5 and 6 panel race designs.



In line Posts. Yards are erected with the post up-side down. Hole marked, panels unbolted, hole dug, post is inverted, adjacent panels bolted and concreted in the hole.

**Topless Race Bows**

Topless Race Bows with Walkway allow uncluttered access to the cattle. A 100mm thick slab is poured and stamped before using the yards. Concrete is level with the base.

Because the concrete is poured with the yards erected there is no need to dismantle the race prior to concreting.



Mixing and matching panel styles with heavier panels and gates in force areas is popular



# Cattle Drafting Options

Drafting cattle is now more frequently required due to changes such as tighter feeder weights, cell grazing, early weaning and overall improved management practices. NSS has developed a series of drafters that allow 1 person drafting. In addition to traditional pound or yard drafting we have a number of products specifically designed to enhance your drafting.

## Basic Draft with Block Gate

Cheaper and more easy to use than the conventional 2 gates in frame. The 2 draft gates are joined at the top with a removable overhead brace. This means the operator only has to push or pull the outside gate to move both gates together. In association with the swivel posts on the headbail/crush the unit allows for quick drafting and access. The block gate (GP 5 rail or Hunter 5 rail only) on the ramp will block an animal if it is missed while attempting to catch it.

**Available in all panel styles.**



Basic Draft in closed position.



Basic Draft. Gates swing in unison. Push Pull one to work 2 gates. Swivel latch posts enable gates to be swung past the head of an animal after catching



Basic Draft swivel posts fold back to give good head access

## Hunter Valley Draft with Baulk Gate

A variation on the Hicks Draft/Baulk Combination. The three stage baulk gate when not being used as a baulk gate forms a well for the operator to stand in if mousing etc. Access is unlimited if performing other husbandry procedures such as dehorning, ear tagging, drenching etc. Access to the headbail is instantaneous.



Hunter Valley Draft.



Rotate spring loaded handle to open off side gate. Locks over centre



On Side draft. Push Pull gate with slam catch

*Note the extra rails in all gates this means that cattle cannot get their head between the rails.*



## The Hicks Draft/Baulk Combination

**Australian Patent No. 2009100838**

Hicks Draft/Baulk Combination has an in built baulk gate with auto catch and release. The off side draft is operated by a rotating over centre locking handle. All gates, off side and on side are operated from the one position and the whole unit can be opened up to transfer cattle from yard to yard.

It combines an auto baulk gate, 3 way draft and outstanding access to the head of an animal. The Drafting Gates operate the same as the Hunter Valley Draft.

Winner Ag-Quip inventors competition 2007. Winner Orange Field Days 2009.



## CCC Speed Draft/Baulk Combination

The CCC Speed Drafter enables 5 gates to be worked from the 1 location. Drafting is as quick as your scales will tare out. There is a manual lever control to the 2 front draft gates via cables enabling a 3 way draft whilst standing at the back of the crush. If an NSS V-Race is incorporated leading into the crush the sliding gate on the V-Race section prior to the crush can also be opened and closed via a direct linkage from this point. Obviously the crush entrance and exit can also be operated from this single position. This system is brilliant when weighing cattle.

If access to the head is required there is an additional manual 3 way draft between the Baulk Gate and the Speed Gates. These Draft Gates operate the same as the Hunter Valley Draft

Every gate on the unit will remain where it is supposed to until moved by the operator (even on a very windy day).

All types of drafting are enabled, e.g. weighing, mouthing, sexing and culling.

The unit also includes a choice of Baulk Gates and quick access to the headbail.



Google national stockyard systems and click on the **YouTube** link to view our products in action.

Luke O'Donnell and daughter Grace, Spring Ridge

*"Weigh and draft cattle using an NSS V Race, Crush and Speed Drafter. The draft gates are at the front of the Speed Drafter and operated by the handles above Luke's head."*



# Curved 'V' Race



1. Design, engineering and strength of materials used eliminates the need for overhead bracing
2. Base is made ready to fill with concrete
3. 1800mm high on outside (discourage jumpers) and rail spacing 120mm (no heads through)
4. 1700mm high on inside (comfortable lean over height). Rail spacing 190mm (can get arms through if required)
5. Noise deadening manufacture process used on sheeting
6. Double walkway standard
7. Clever gate hinging results in gates swinging over 90 degrees (instead of flopping onto the ground)
8. Middle bend restrains animals better in race (instead of a straight V that others use)
9. Available straight or curved (6.2m radius)

**On our property at Nelsons Plains we trade around 500 to 600 steers a year. Deborah relaxing and happy after she and Murray weighed and 3-Way drafted 338 steers in under 3 hours.**







**We also sell the full range of Tru-Test Weighing and Identification Solutions for Livestock Management.**

**Thus we are a one-stop shop.**

### **Weigh Box**

Inbuilt Concrete Floor. Quieter and scales will tare out quicker. Tapered sides so the animal will not attempt to turn around. Split Slide gate entry. Dual handle operation available.

Gate on off side in case an animal goes down. Large EID Reader mounting board. Off Side rail spacings eliminate cattle getting their head between the rail. On Side spacings allow good access for backlining, needling etc, if the Weigh Box is being used as part of the race. Rails on top prevent an animal climbing. Adds to the length of the race if processing cattle through the crush or back lining, needling etc. cattle. As with all the products we sell our weighbox is 100% manufactured at our Rutherford factory using first grade Australia Steel.

***Our delivery truck has seen a lot of eastern and central Australia***





# Remote Control Air Operated Cattle Processing

Winner Award of Excellence Australian National Field Days 2016



## Complete remote operation that imitates manual operation

Cattle flow and processing is greatly enhanced. This is due to:

- There is much less walking for the operator/s. There is no time wasted walking to and from a gate. Thus cattle flow is better, as there are less stoppages.
- Fatigue associated with distance travelled around the yards and operation of manual controls is minimized
- Cattle flow is not interrupted by having to walk up in front of their travel to open a gate. This stops leaders from baulking in the race or turning around in the force.
- Cattle will be less stressed as you process because you are not in and out of their flight/fight zones to open and close gates.

A choice of Mains / Generator powered or 12 volt battery.

A 1.5 – 2HP compressor is adequate.

- Speed and pressure can be individually adjusted for each ram.
- Toggle control imitates manual operation with incremental opening and closing of the head bail and squeeze. This is the only mobile remote operation available with this feature. The ratchet and pawl still hold the head bail and squeeze. Catching cattle effectively with a system where the head bail is either completely open or shut is impossible.
- The Controller is worn around the waist to leave both hands free and the operator is completely mobile around the yards. Thus the operator is not limited to operating the controller in the small arc that a swing arm off the side of the crush allows.

- The controller can be customized to suit your requirements. (eg whether you are right or left handed).
- There is a kill switch on the controller which instantly deactivates the system and releases all air pressure. Thus everything is not locked in a fixed position if power is lost.
- The whole system can be operated manually if you only need to process a few or if the power goes down.
- Manufactured in Australia from German engineered components.
- Additional hand held controller available that enables a helper to remotely open and close race slide gates as they seem fit. The main operator can concentrate on their job knowing the cattle will keep coming. A big plus is that the helper is not walking up and baulking cattle.
- Up to 9 gates/headbails/squeeze can be operated by single the controller.
- Full remote control within a 90 metre radius

If you wish to still operate the crush 100% manually there is a Button Controlled 2 or 4 gate system available for remote drafting and/or slide gate opening and closing.



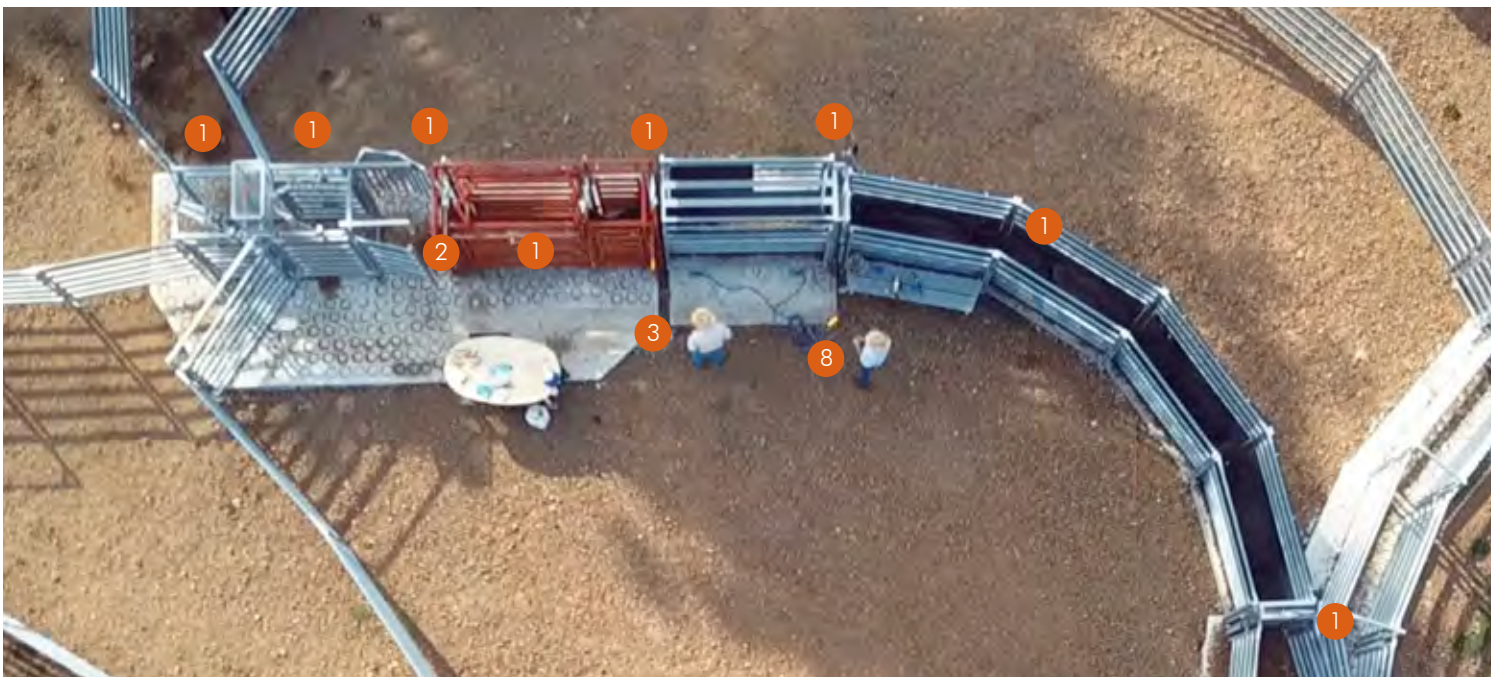
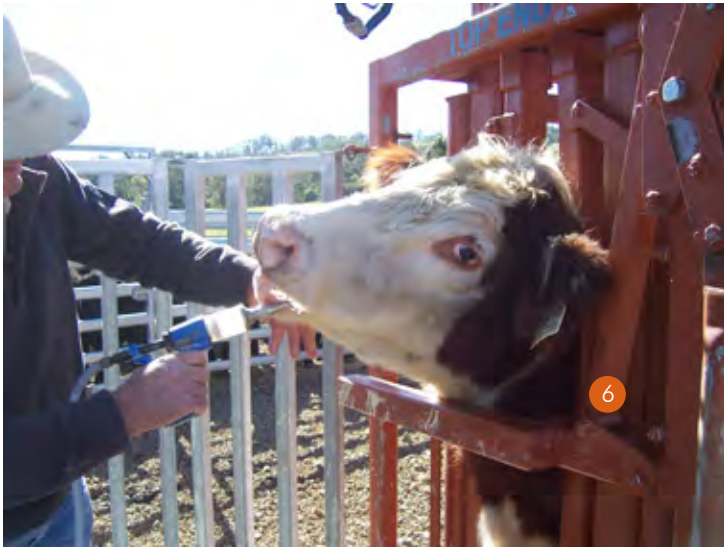

The Award of Excellence recognises new, innovative design and manufacture of machinery and equipment designed for use in the Australian agricultural industry, and is an acknowledgement that the product meets high criteria standards and is worthy of the attention of primary producers.



Most cattle sales \$ proceeds are solely a function of weight and quality in cents / kg. (And is a big influencer in breeding and stud stock). Even at most store sales, buyers are trying to estimate the weight combined with cents / kg for their bid. Scales will assist your objective management instead of relying on best guess management.



This animal will be close to a curfew weight of 500 kgs in 3 weeks.



This animal looks healthy but the scales revealed it was not performing. Was it nutrition, parasites, water quality, a mineral deficiency or stress etc. that was causing the weight loss? The trough water was tested and excessively high iron levels were identified.

## The Ron Booth Circular Processor

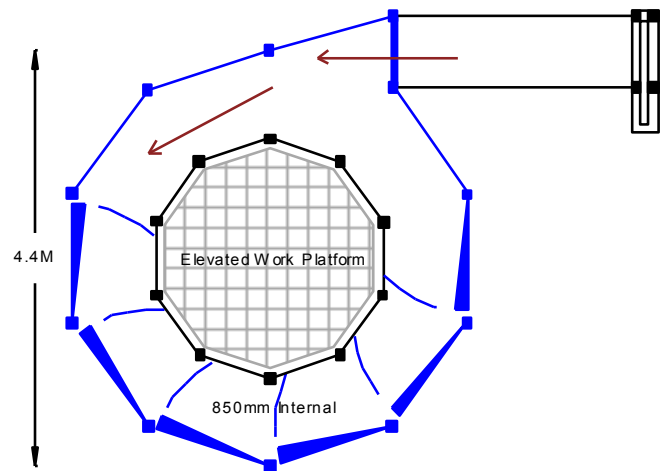

“One of the best parts of the business is that I get to spend some time with some really good operators. One of these good operators is Ron and Lorraine Booth from Wandoan, Qld. After Farm Fest about 5 years ago Ron and Lorraine invited Deb and I to have a look over their place and design their second set of yards that they have since purchased from us. Ron showed us one his old timber yards that he built in the 1970’s. In it was a wooden processor that Ron used for drafting and back lining”.

Because of the tight circle cattle cannot get a run up, so it is ideal for completely safe drafting and very quick back lining. Both operations are done standing on the raised central platform. Handles control the drafting gates. If animal is missed in the draft or the operator needs more time for a decision it goes around again and joins other cattle entering.

The circular processor can be linked with an air operated yard. Thus the one toggle or button controller can operate this as well as a complete air race, crush, and draft.



# Important considerations when purchasing a yard

- **Is quoted capacity based on some mythological total holding capacity or a realistic working capacity?**  
Many quoted figures are unrealistic. Overcrowding is the biggest cause of accidents
- **Are all necessary ground pins, caps etc supplied or are they an extra?**  
These add-ons are often expensive or not available. Tent pegs will not suffice.
- **Yards will move if they are not pegged down.**  
Despite what you may be told.
- **Does the race look longer than it actually is as a result of the very short panels used in the race?**  
Some suppliers use between a 1.4M panel and a 1.8M panel. 4 of others same length as 3 of ours.
- **Are there man ways or gates to provide adequate access around the yard?**  
Hidden extra costs. Plus retro fitting a man way will require a force yard to be redesigned.
- **Do man ways only swing in? People may be hurt and an animal may be trapped by the head.**  
You may be rammed into the man way. Also a beast's only reaction is to suck back.
- **Are man ways too narrow? (A narrow man way will catch a beast in between the ribs and the hips.)**  
Is a major problem if this happens.
- **Will the gates get broken off their hinges if the gates are hinged inside the yards? Do gates cross over?**  
Gates need to fold back 180 degrees and lay flush against a panel.
- **If there are slam catches, are there backing plates to stop an animal from rolling the catch?**  
Gates can be easily opened by a nose, tail bone or horns.
- **Are there tear or bruise points though gates with drop pins or slam catches that protrude?**  
Remember you are nearly always on the opposite side to the latch side which is hit by animals.
- **Do all pound gates face the same way? Pound drafting with opposite swinging gates is cumbersome.**  
The designers have never used a pound.
- **Can you swing the draft gates at the front of the crush past an animal's head while it is still in the head bail? Are gate frame posts or joining posts at the front of the head bail a knuckle buster.**  
Have to back animal into crush prior to drafting. No give when hand between head and steel
- **If you miss catching an animal will it keep going up and over the load ramp?**  
Can be a fair bugger.
- **Are entry gates and gates in the yards wide enough for cattle flow?**  
50 - 100 head though a 2 metre wide opening is slow and results in bruising.
- **Can an animal get it's head between the sliding gate rails?**  
A real problem if you cannot open the slide with other animals jamming it.
- **Are all races, ramps and crushes clearances over 700 mm wide?**  
Cattle are getting lower, wider and heavier.
- **If a timber floor in the ramp, can boards be added to easily, or, is it a cut and re weld exercise? Timber floors will shrink and additional boards will need to go in the floor over time.**  
Easy to break a leg.
- **Will trucks shunt the ramp back and crumple the yards?**  
Will happen if the ramp is not anchored into the ground.
- **Is the length of the ramp exaggerated by a diagonal claim instead of a horizontal measurement?**  
Is the steel Australian Made Grade 350 – 450 High Tensile or cheap imported steel or panels Grade.
- **250 Low Tensile? Is the wall thickness and galvanizing exaggerated?**  
Imported panels may look like Australian cattle rail but they are often only Grade 250 & 1.8mm thick.
- **Are prices quoted GST inclusive (as per the law)?**





### NSS48-3PCR

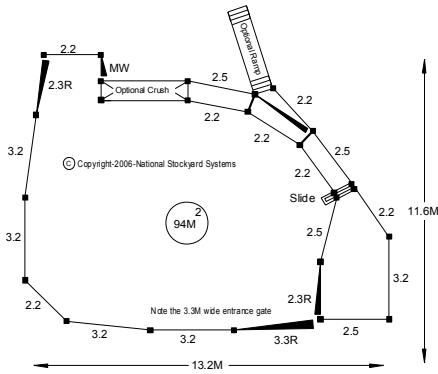

Total yard area is 113 square metres  
(work 48 head hold 81 head)

### NSS50-2PSR-RF

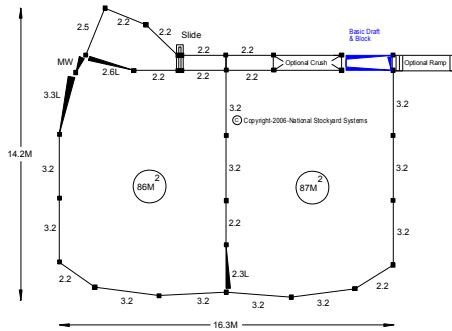

Total yard area is 189 square metres  
(work 50 head hold 135 head)

### NSS78-3PCR-RF

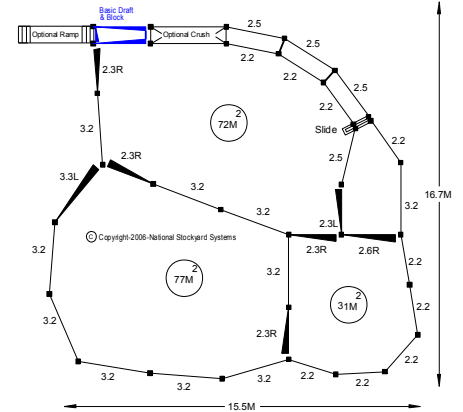

Total yard area is 198 square metres  
(work 78 head hold 141 head)

### NSS78-3PCR-RF CALF

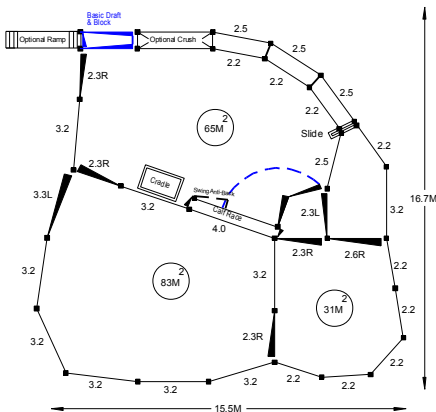

Total yard area is 202 square metres  
(work 78 head hold 141 head)

### NSS80-3PCR

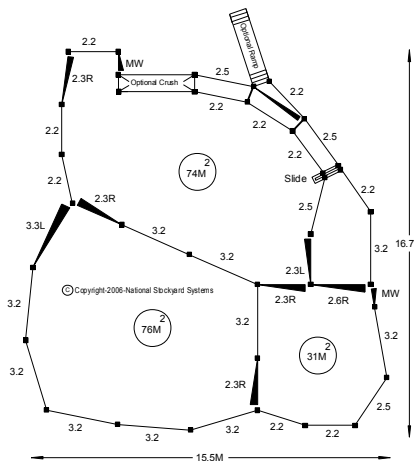

Total yard area is 199 square metres  
(work 80 head hold 142 head)

### NSS88-3PCR-RF

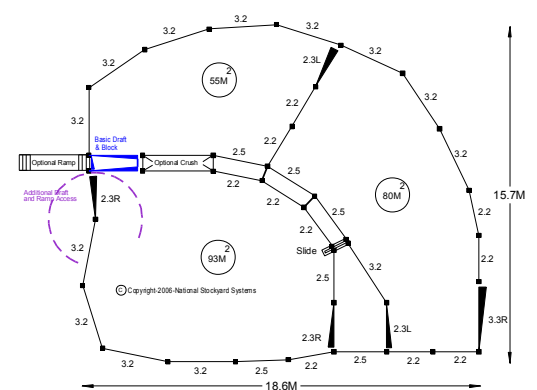

Total yard area is 248 square metres  
(work 88 head hold 177 head)

### NSS98-3PCR-RF

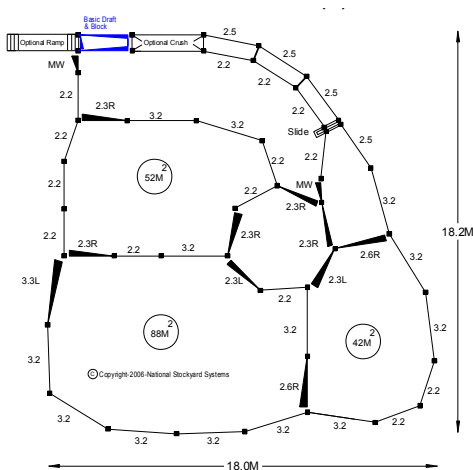

Total yard area is 259 square metres  
(work 98 head hold 183 head)

### NSS100-3PCR

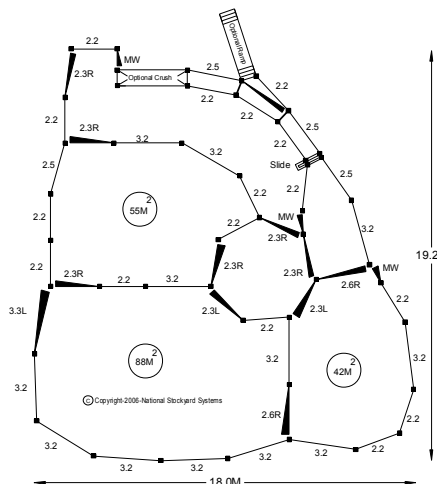

Total yard area is 261 square metres  
(work 100 head hold 186 head)

### NSS100-3PCR-CALF

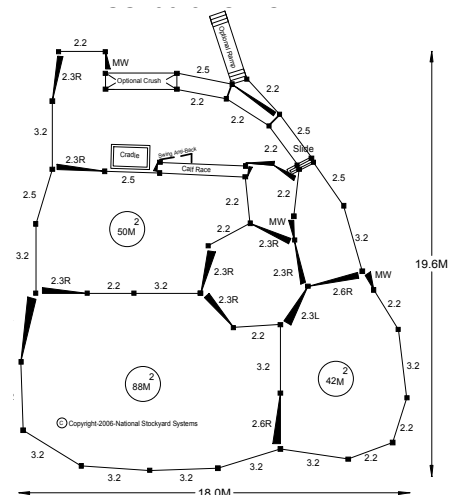

Total yard area is 260 square metres  
(work 100 head hold 185 head)

**Quote: Murray Schaefer** "The literature and the web are littered with diagrams and explanations of flight zones and cattle movement. Many refer to exact diagrams of *points of balance, edge of flight zone, movement initiation point, 45 degrees to the wither, 90 degrees to the eye, blind spots, edge of flight zone etc. etc.*" Basically to try to key hole every animal this way is garbage. All of the above will vary depending on the handler's presence, the individual animal, temperature, time of day, yard surface, wind, previous association with handlers, dogs, timing and direction of handler movement etc. No two animals are the same. If you do not believe me then go and watch a campdraft. No two runs are the same. **I believe that efficient stock handling can be summed up as – correct position, timing and amount of pressure, and, correct timing and release of pressure - ."**

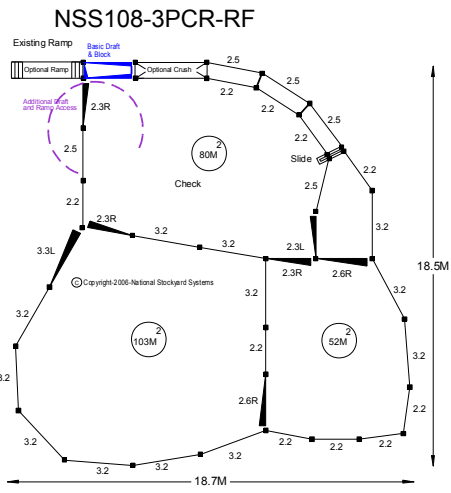

Total yard area is 256 square metres  
(work 108 head hold 183 head)

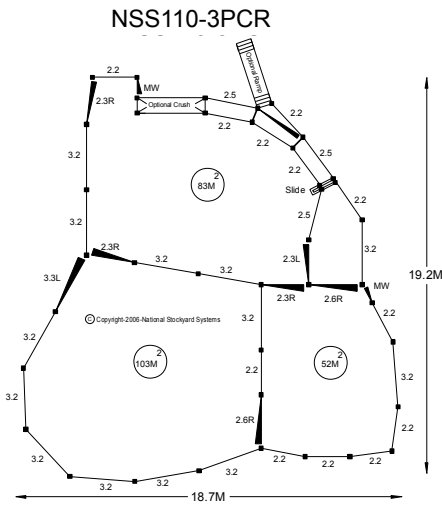

Total yard area is 259 square metres  
(work 110 head hold 185 head)

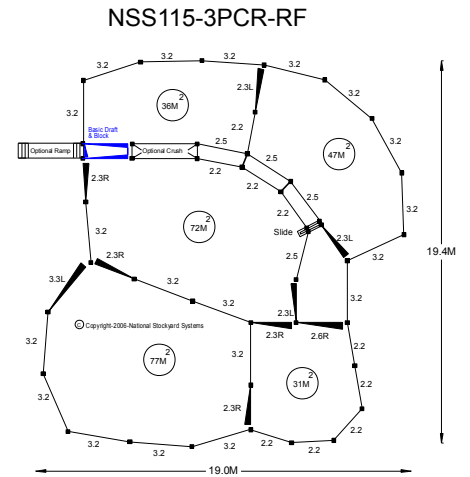

Total yard area is 282 square metres  
(work 115 head hold 201 head)

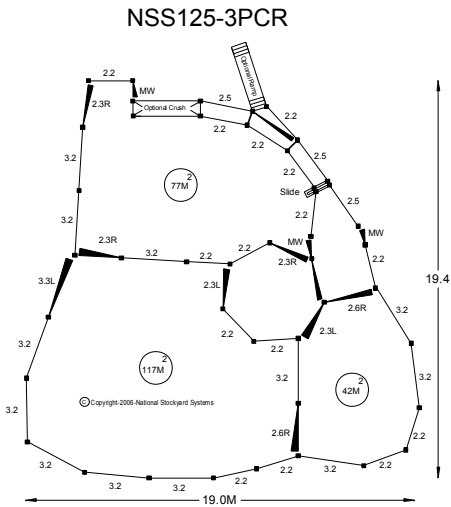

Total yard area is 270 square metres  
(work 125 head hold 193 head)

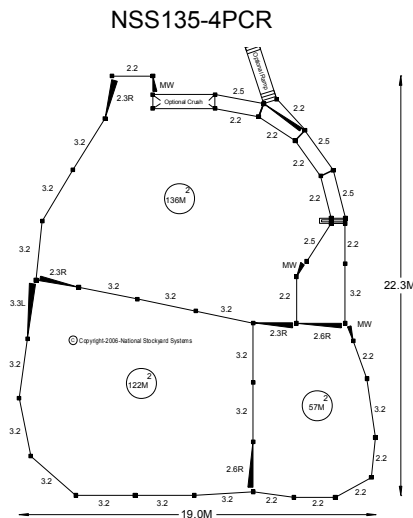

Total yard area is 338 square metres  
(work 135 head hold 277 head)

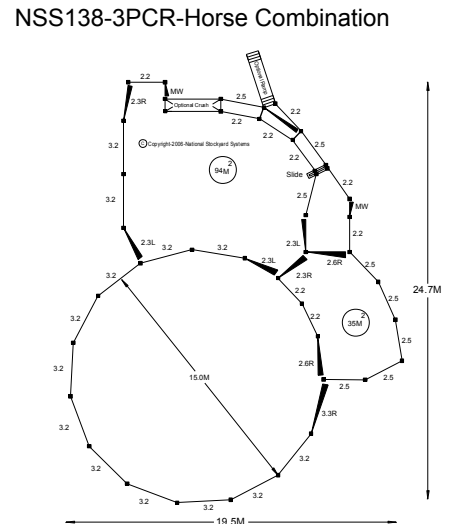

Total yard area is 324 square metres  
(work 138 head hold 231 head)

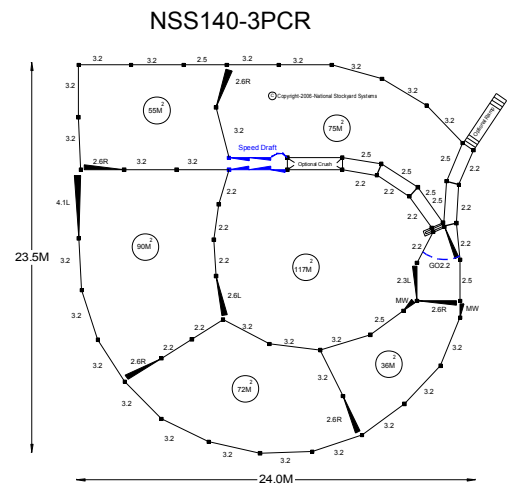

Total yard area is 470 square metres  
(work 140 head hold 336 head)

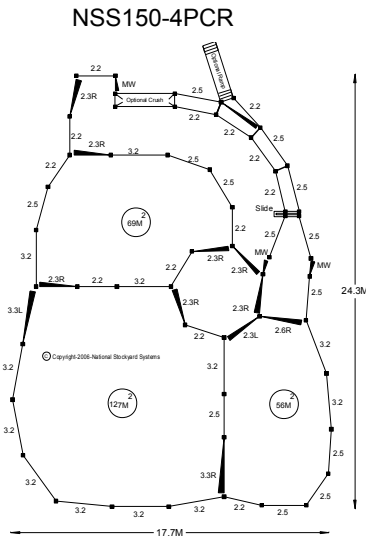

Total yard area is 340 square metres  
(work 150 head hold 243 head)

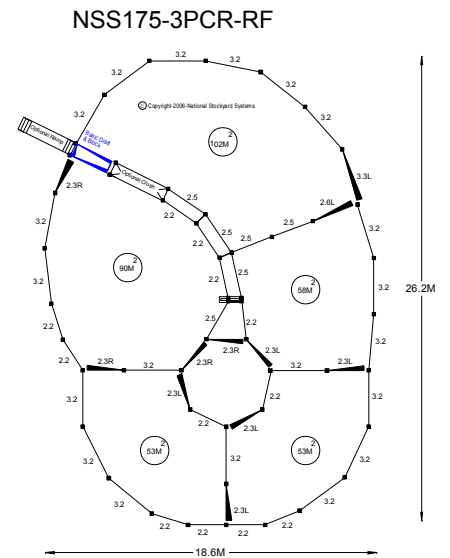

Total yard area is 387 square metres  
(work 175 head hold 276 head)



**Comparison plans are not to scale please check individual scale for accurate dimensions.**









NSS420-5PCR

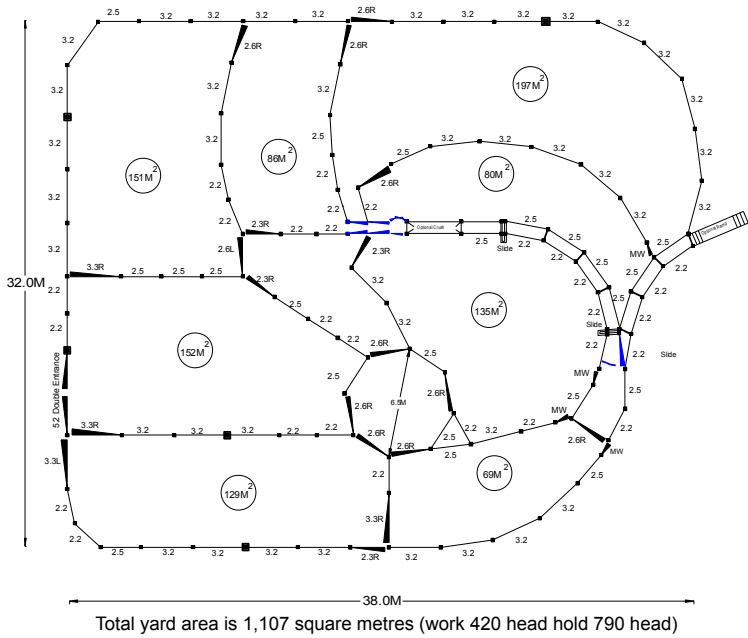

NSS550-5PCR

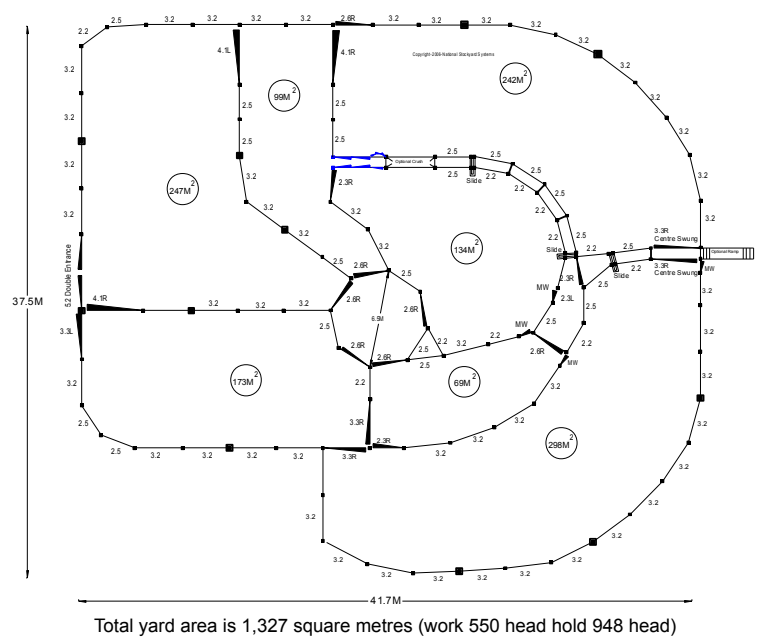

NSS1000-6PCR

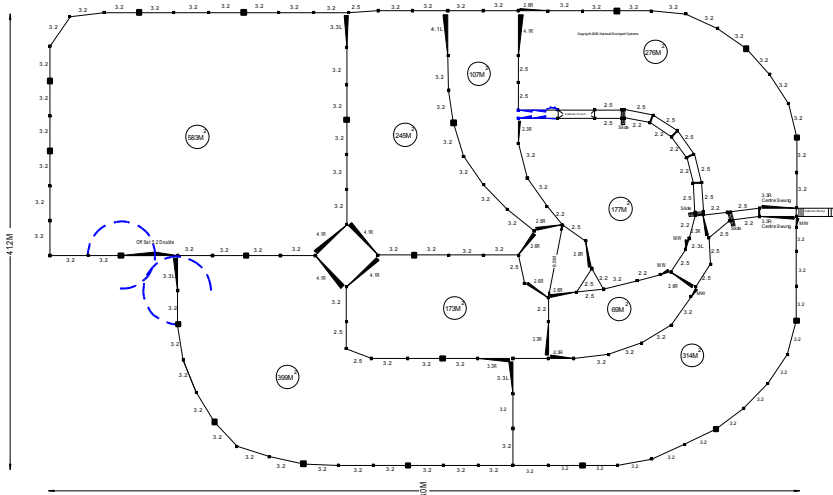

Comparison plans are not to scale please check individual scale for accurate dimensions.

NSS1250-6PCR-CFA

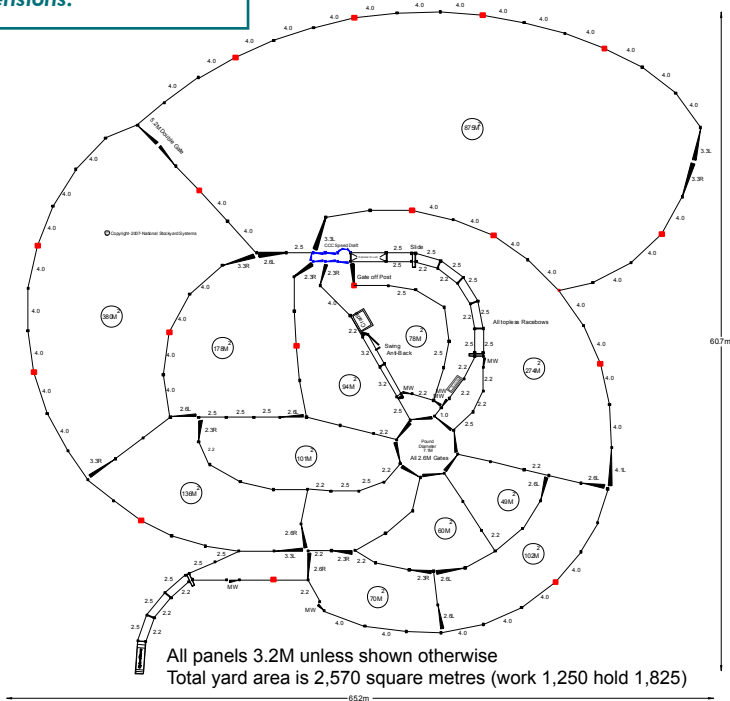

The longer panels utilised in non-pressure areas result in yards larger than they appear on paper

Calf marking facilities can be easily added to most yards



A well designed race entry yard and correct operator body position aids flow from the race entry yard into the race.

(Many of the problems that people experience when working their cattle are poorly designed "force" yards and a lack of understanding of body position in relation to cattle flow, and cramming too many in the force).



A calf race can be added to any of these plans









# Rotary Force Options

Although our normal force is designed for ease of cattle flow into the working race, some clients prefer a rotary force. We have developed two options. The first is a budget rotary force for working small numbers of cattle. The budget rotary force quickly transforms from a force yard to an extra panel of race. The second is a combination force for larger yards.

Google national stockyard systems and click on the **YouTube** link to view our products in action.

## Budget 90° Rotary Force (available in all panel styles)

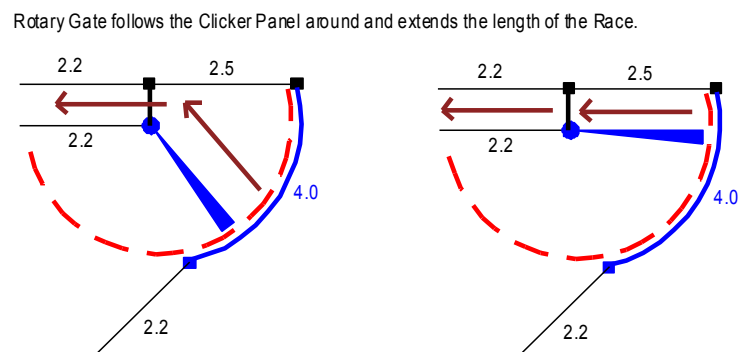
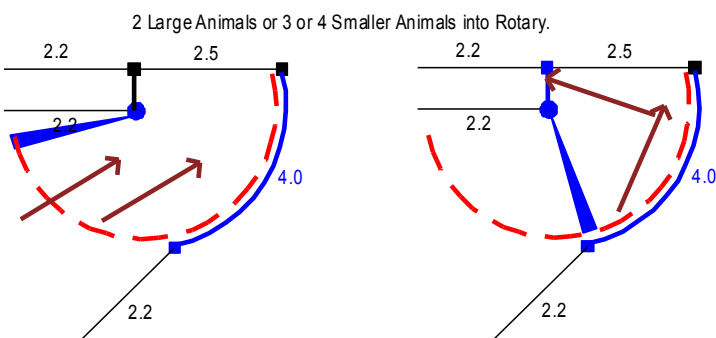



NSS25 (BR) - 2PSR

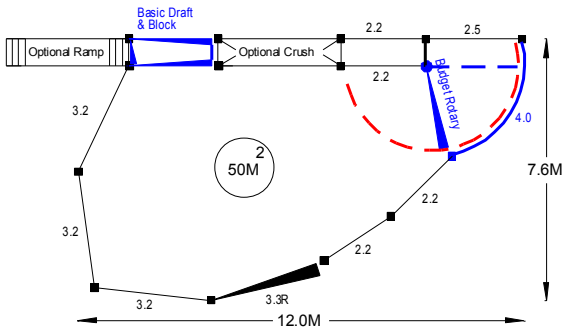

Total yard area is 62 square metres (work 25 head hold 44 head)



Bill Munton. Millers Forest

"Our budget rotary at home is the best thing since sliced bread."

NSS26 (BR) - 2PSR

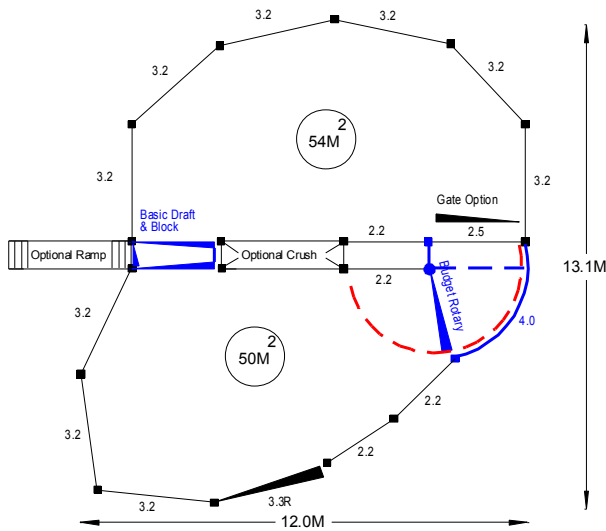

Total yard area is 115 square metres (work 20 head hold 82 head)

NSS45 (BR) - 3PSR

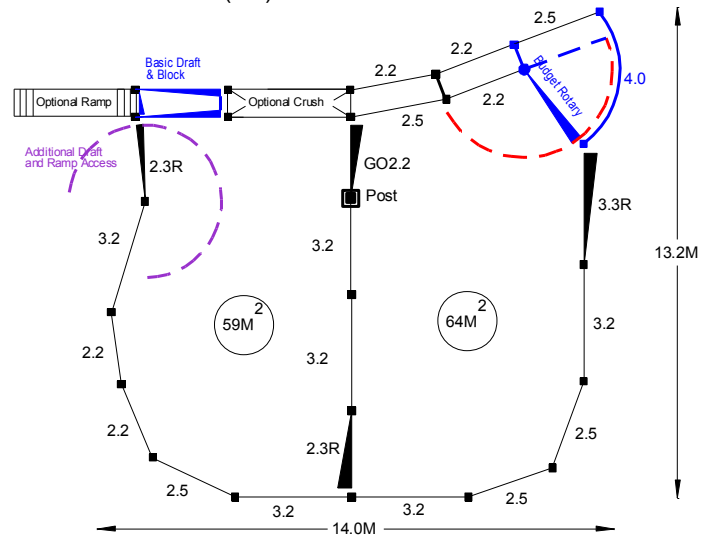

Total yard area is 137 square metres (work 45 head hold 98 head)

NSS75 (BR) - 3PSR - CFA

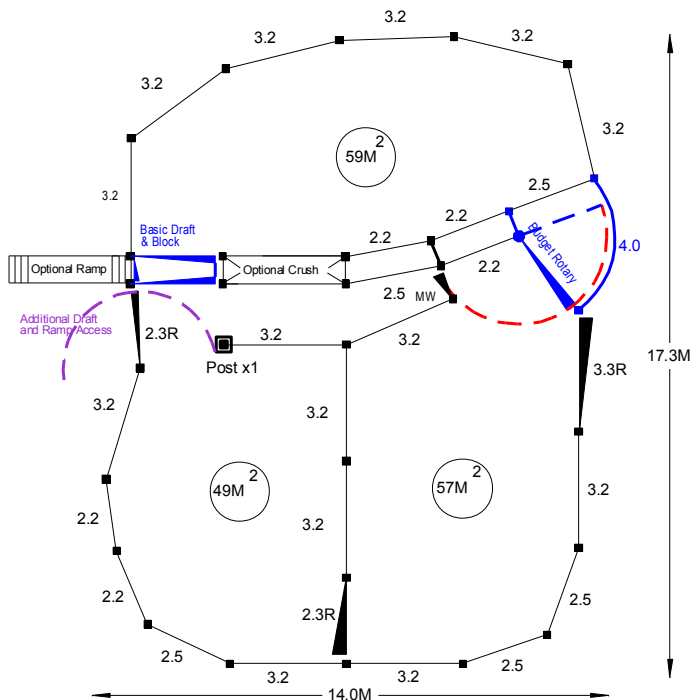

Total yard area is 196 square metres (work 75 head hold 120 head)

NSS85 (BR) - 3PSR

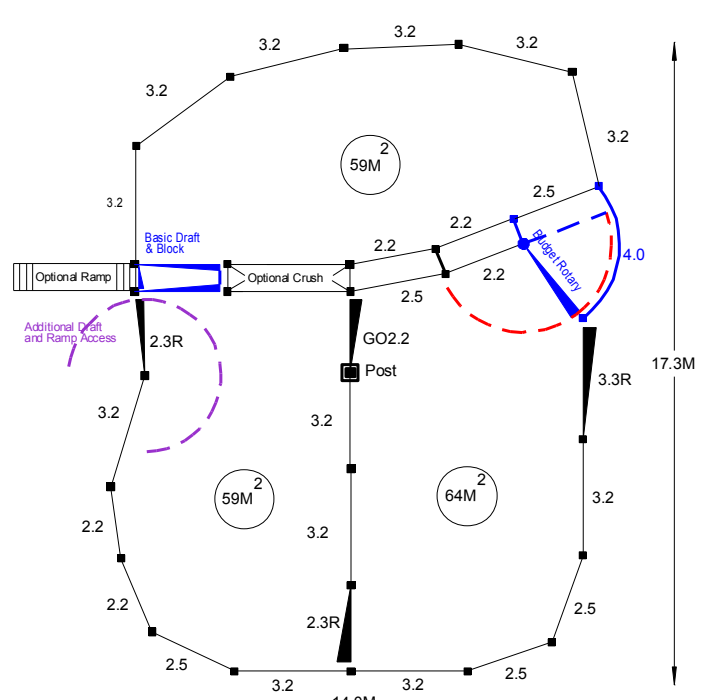

Total yard area is 196 square metres (work 85 head hold 140 head)

## Combination Force®

Our Rotary Force is extremely heavy construction with most of the RHS 75 x 50 x 3mm. The curved outside is 4 metres in length and gate radius is 2.5 metres long. It also includes a Manway for access if required. This Rotary Force is designed in such a way that the rotary gate the does not have to be always activated to load the working race



Note how the curved rotary gate in frame minimises the bad corner that is associated with straight gates



Heavy duty construction & the unique design allows for the force to be used as a conventional force or as a rotary force if needed



Our Combination Force® can be used as a conventional force or as a rotary force

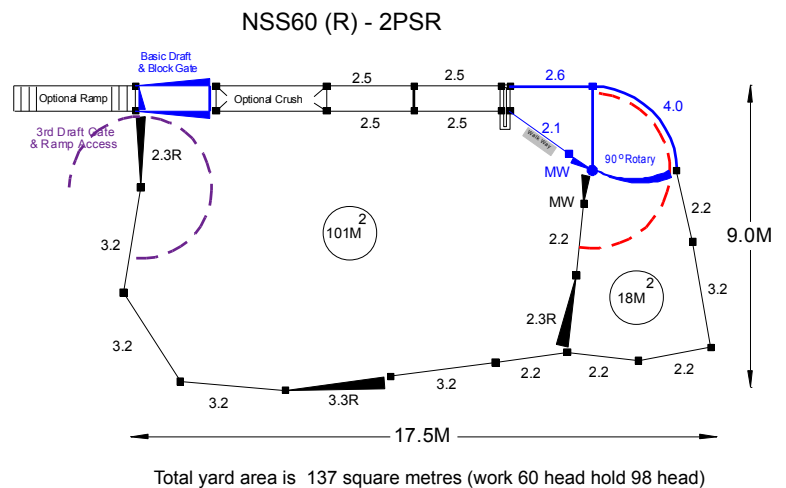



### 90° Rotary Force

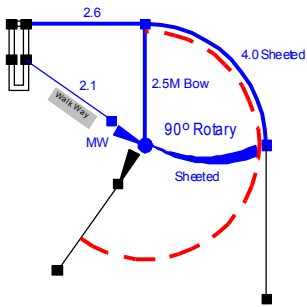

### 90° Rotary Force

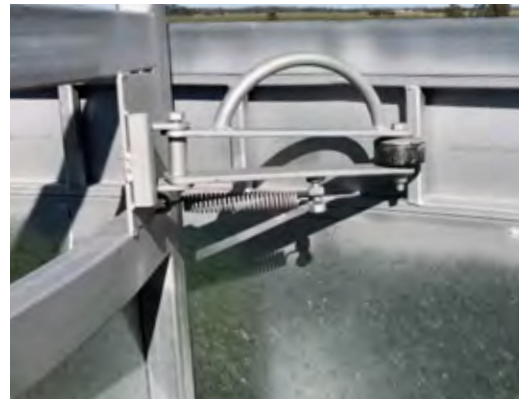
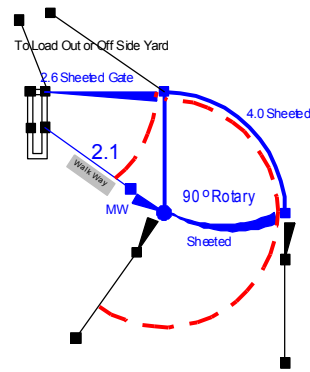

### NSS80 (R) - 3PCR -RF

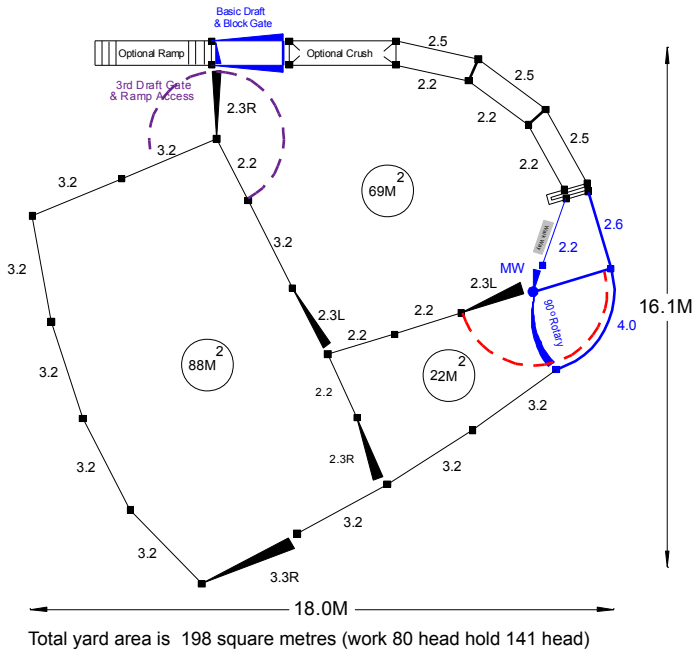

### NSS120 (R) - 3PCR-RF

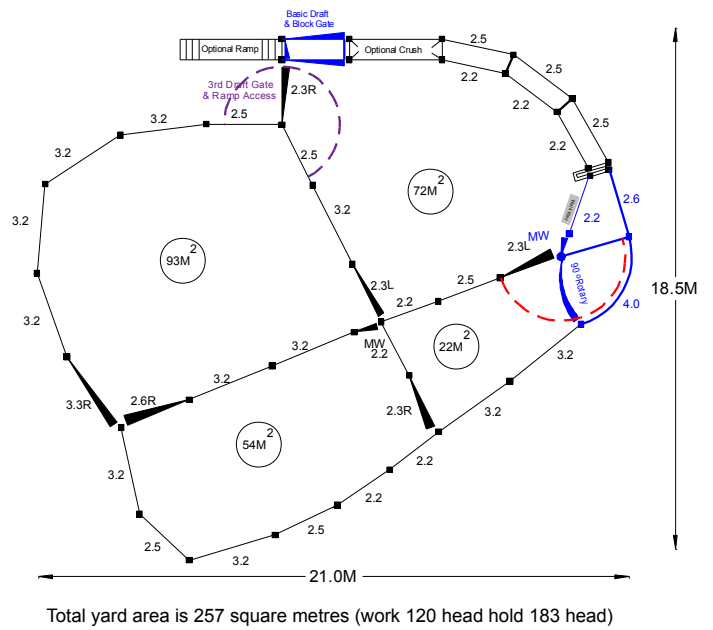

### NSS121 (R) - 3PCR

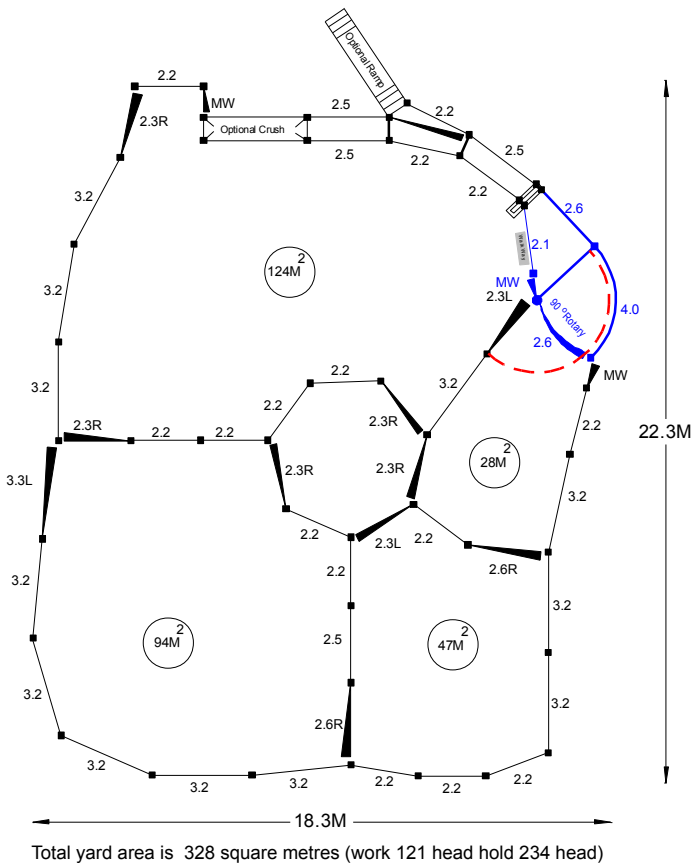

### NSS122 (R) - 3PCR

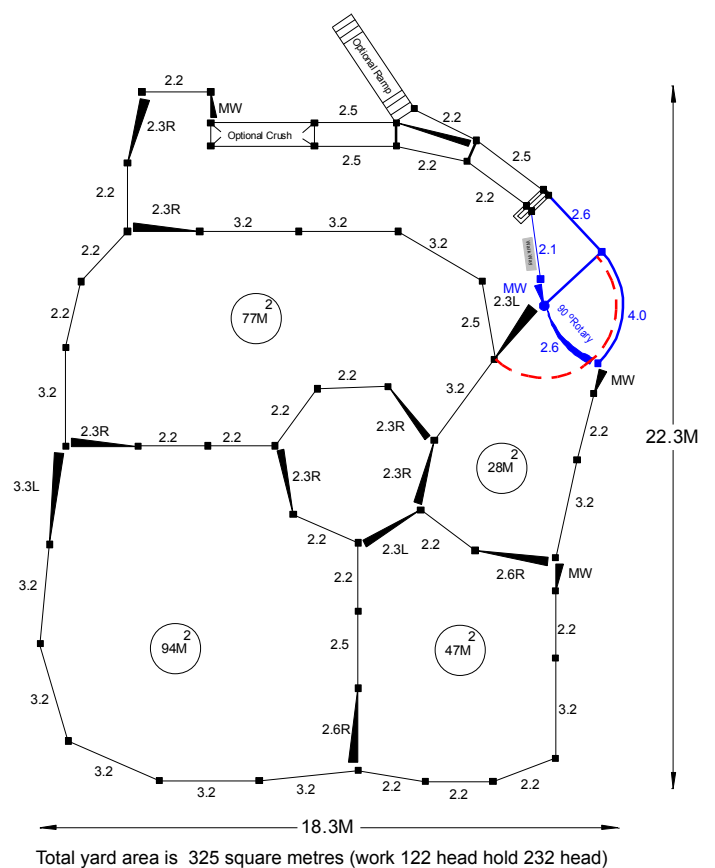

The codes of the yards refer to average working capacities not a mythological made up figure that some other yard suppliers quote.

The NSS Number will work that number of average size cattle. (A bit like a kitchen 8 people can stand in it but only 2 people can work in it - and if you had 8 people standing in a kitchen nobody could work in it).

NSS122 (R) - 3PCR-CALF

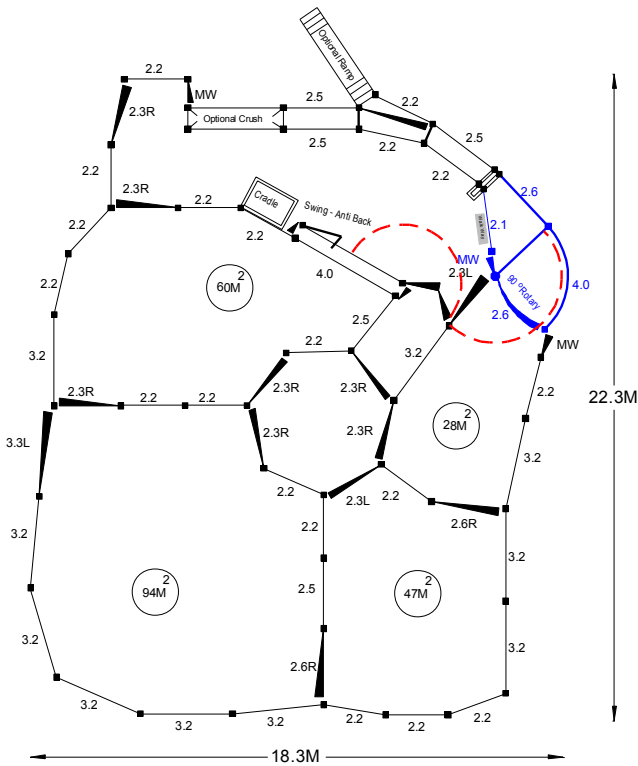

Total yard area is 325 square metres (work 122 head hold 232 head)

NSS125 (R) - 4PCR-RF

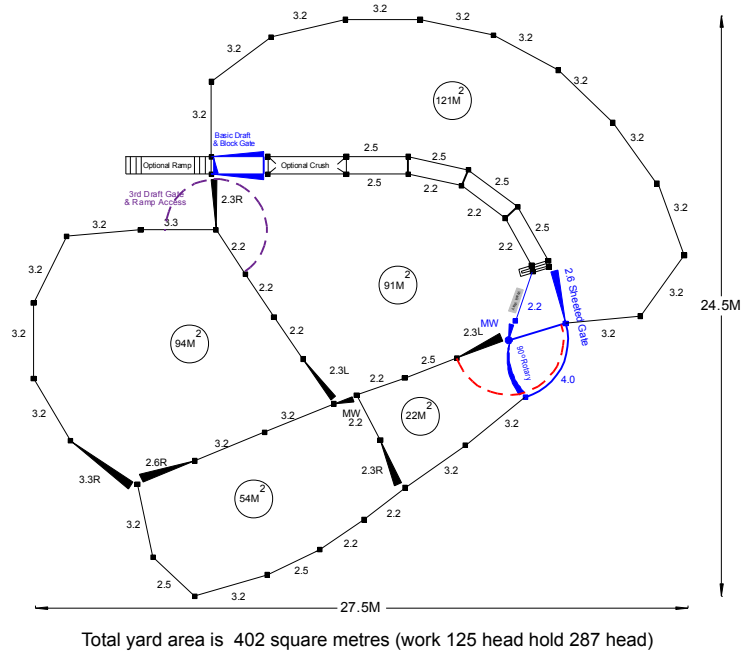

Total yard area is 402 square metres (work 125 head hold 287 head)

*A calf race can be added to any of these plans*

*Comparison plans are not to scale please check individual scale for accurate dimensions.*

NSS170 (R) - 4PCR-RF

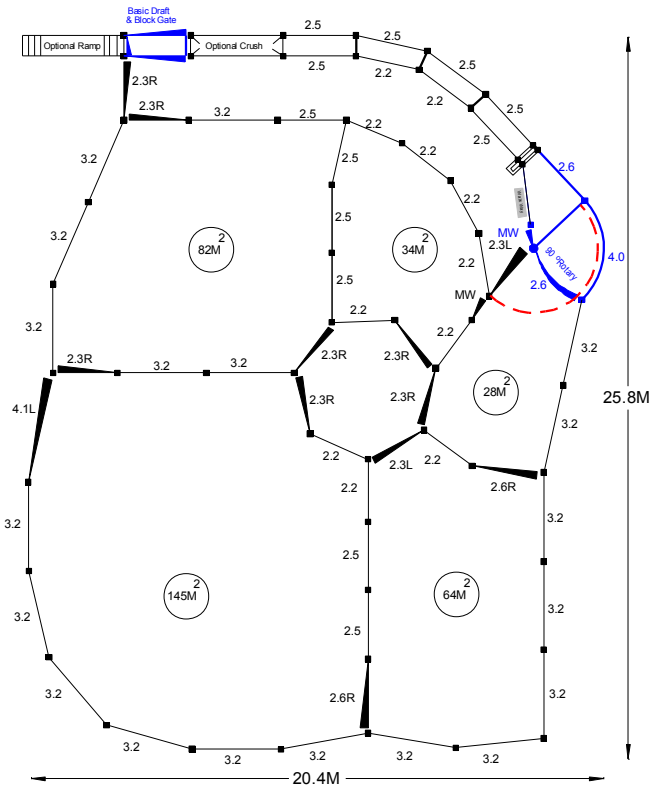

Total yard area is 430 square metres (work 170 head hold 307 head)

NSS235 (R) - 4PCR

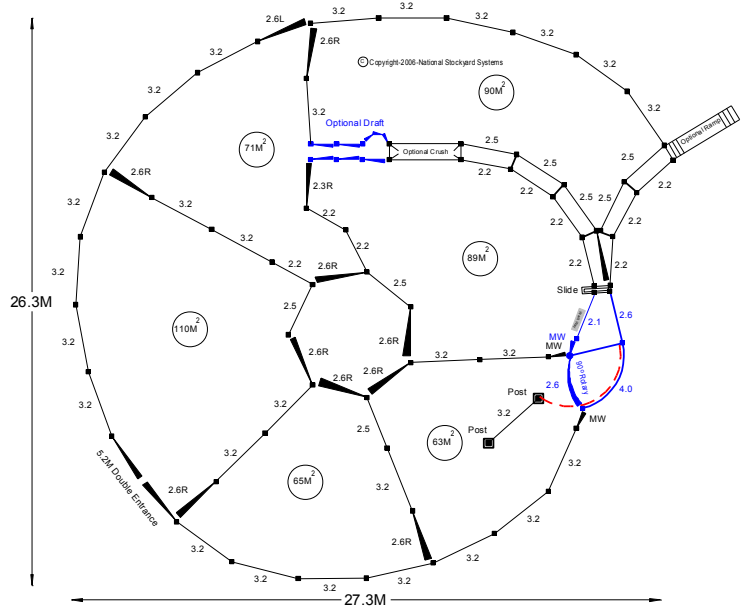

Total yard area is 540 square metres (work 235 head hold 386 head)



# Low Stress Stock Handling

Low Stress Stock Handling is an advanced, yet easy to learn method of handling all classes of livestock. LSS teaches us how we can increase animal productivity by working with the animals, not against the animals. LSS gives people the skills to be safe in stockyards. LSS begins in the paddock and is beneficial to both the operator and the animal right through to marketing. It is important to combine these stockhandling skills with a properly designed set of yards. The most important feature of these yards is the Bud Box. The end result of LSS effectiveness is completely dependent upon attitude. LSS will save you time in both paddock and yard and your stock will perform better.

NSS (LOW STRESS) 20-3PCR

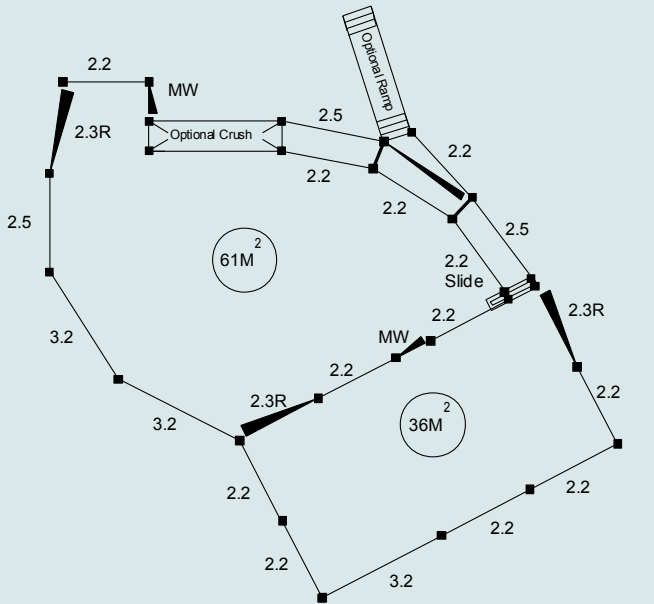

Total yard area is 106 square metres (work 20 head hold 75 head)

NSS (LOW STRESS) 75-3PCR

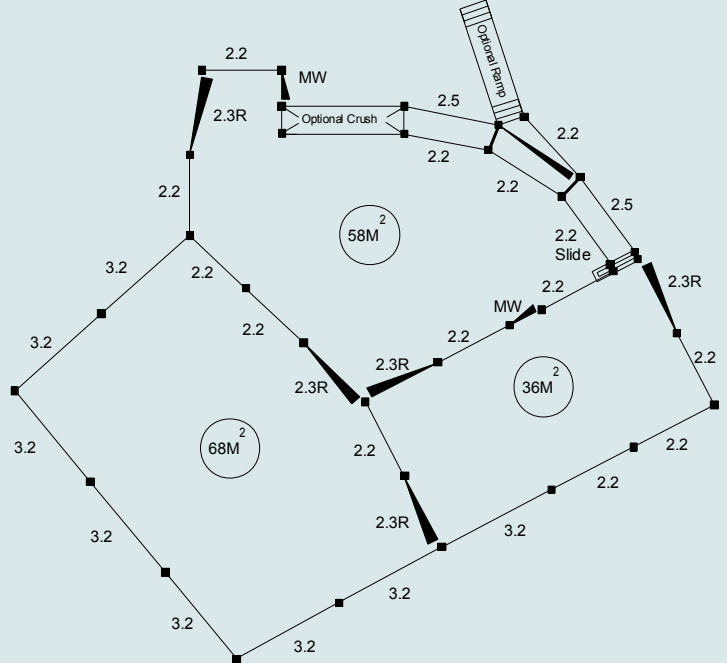

Total yard area is 171 square metres (work 75 head hold 122 head)

NSS (LOW STRESS) 76-3PCR

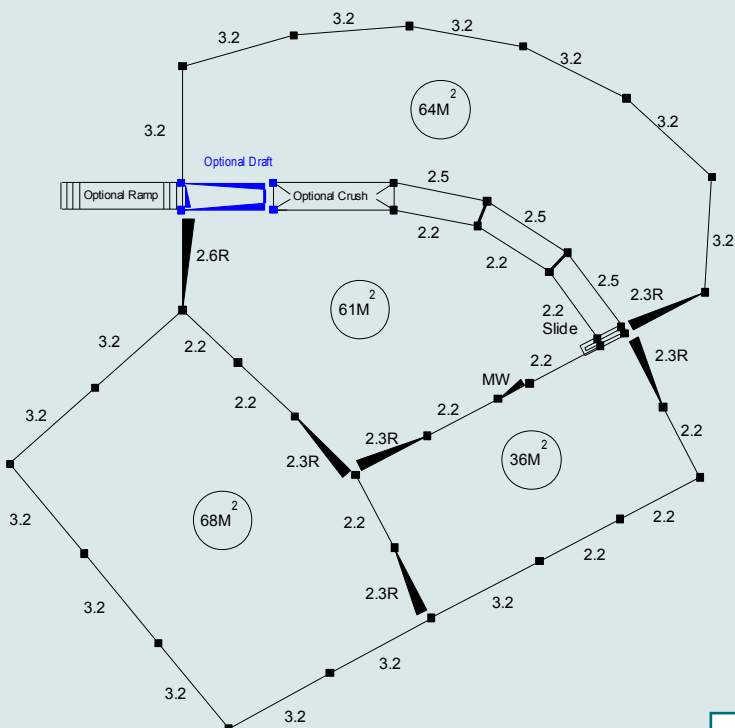

Total yard area is 238 square metres (work 76 head hold 170 head)

NSS (LOW STRESS) 125-3PSR

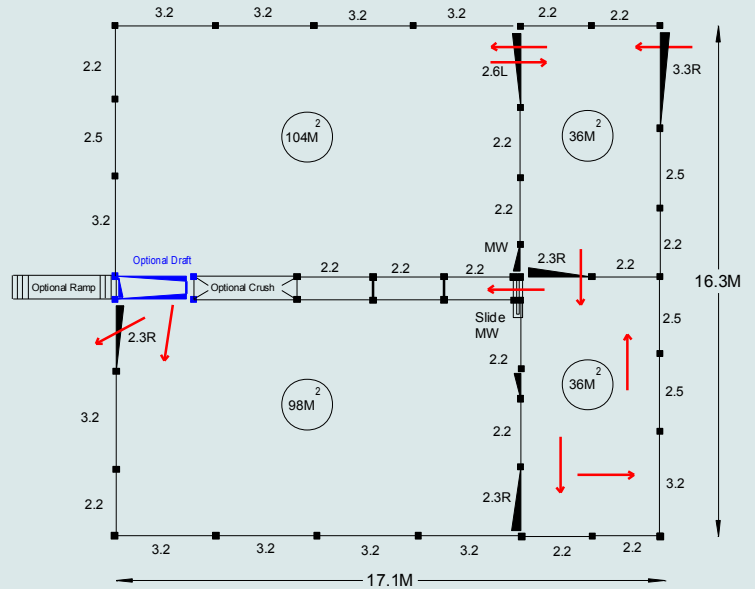

Total yard area is 238 square metres (work 125 head hold 200 head)

A calf race can be added to any of these plans

Comparison plans are not to scale please check individual scale for accurate dimensions.

### NSS (LOW STRESS) 160-4PSR

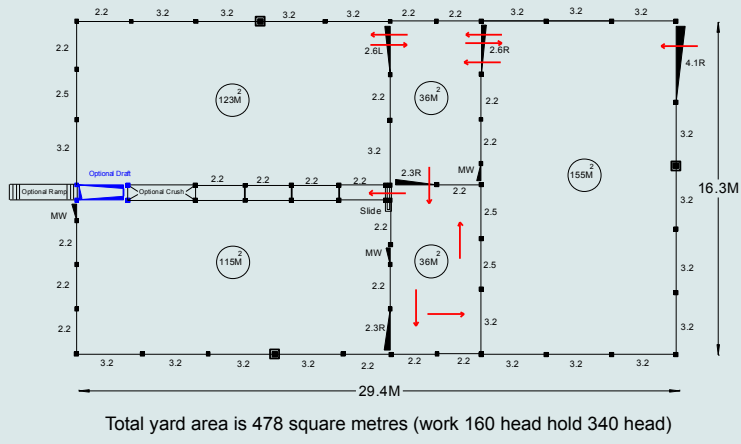

### NSS (LOW STRESS) 210-5PSR

Total yard area is 779 square metres (work 210 head hold 550 head)

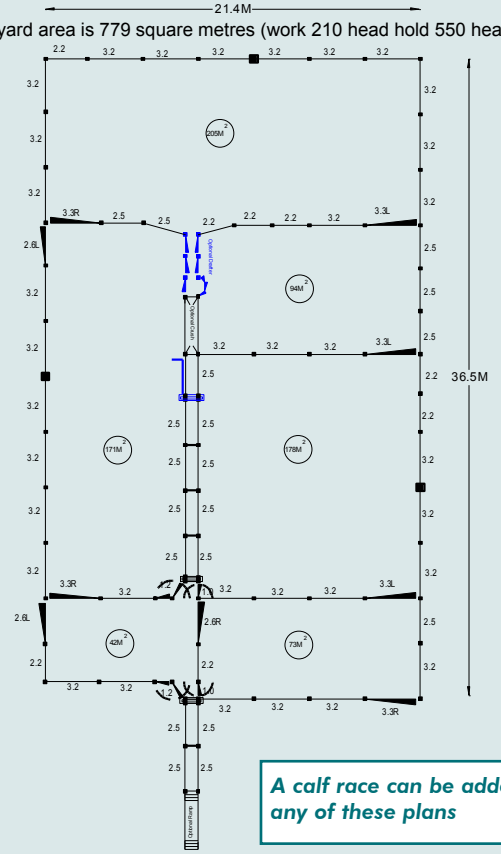

### NSS (LOW STRESS) 250-4PSR

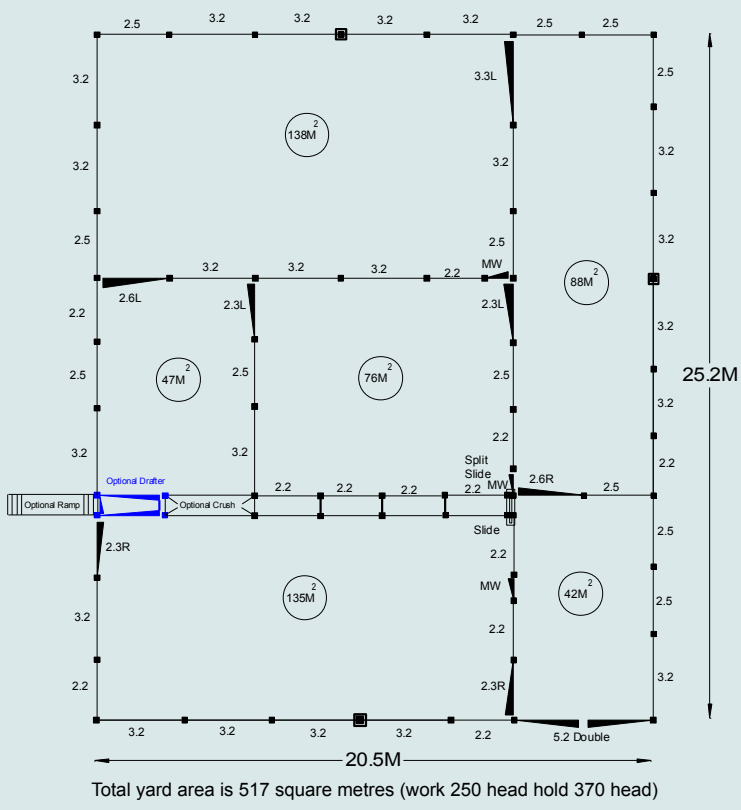

### NSS (LOW STRESS) 300-6PCR

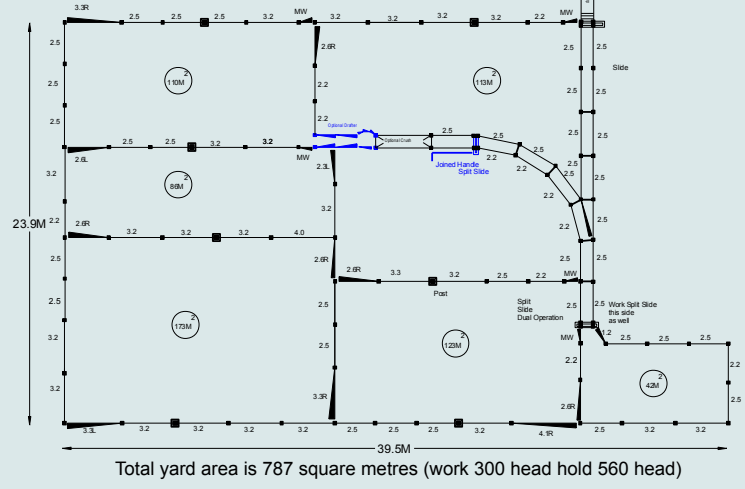

Participants watching and being involved with an LSS School run at Yoerval by Grahame Rees. Graham runs numerous schools right across Australia each year. Graham can be contacted on 0428 953 925 or [peneena@bigpond.com](mailto:peneena@bigpond.com) or via website: [www.lss.net.au](http://www.lss.net.au)

LSS will improve your stock handling and bottom line  
**National Stockyard Systems can design a yard system to suit your low stress stock handling requirements**





**1. Muster**

NSS (LOW STRESS POUND) 350-6PCR

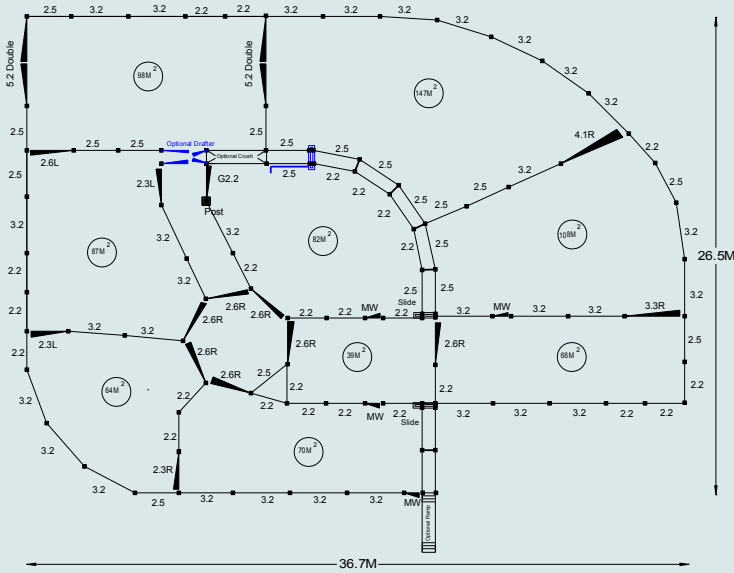

Total yard area is 826 square metres (work 350 head hold 590 head)

*Comparison plans are not to scale please check individual scale for accurate dimensions.*



**2. Process**



**3. Return to paddock(s)**

*It's easy as 1,2,3 with a well designed functional yard*

NSS (LOW STRESS) 2,000-6PSR

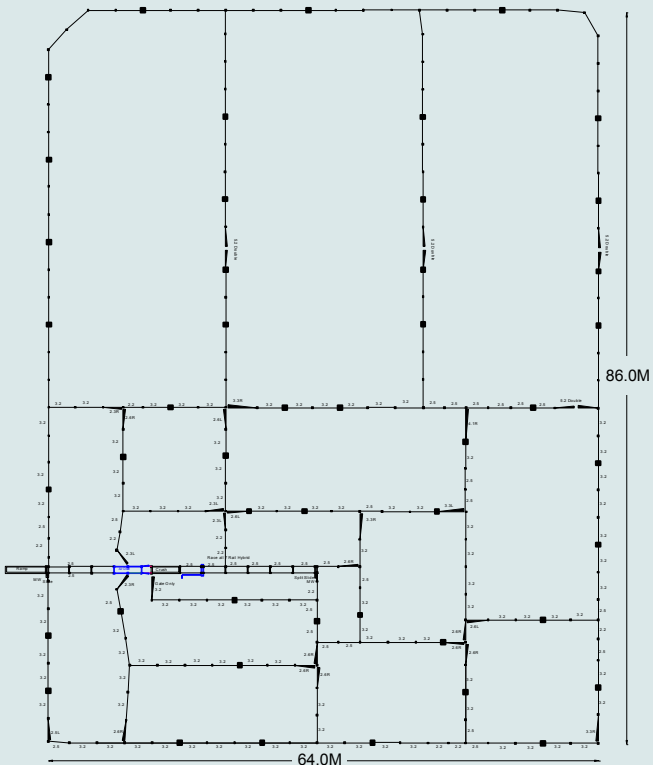

Total yard area is 5,400 square metres (work 2000 head hold 3,500 head)

NSS (HYBRID LOW STRESS) 2,100-10PCR

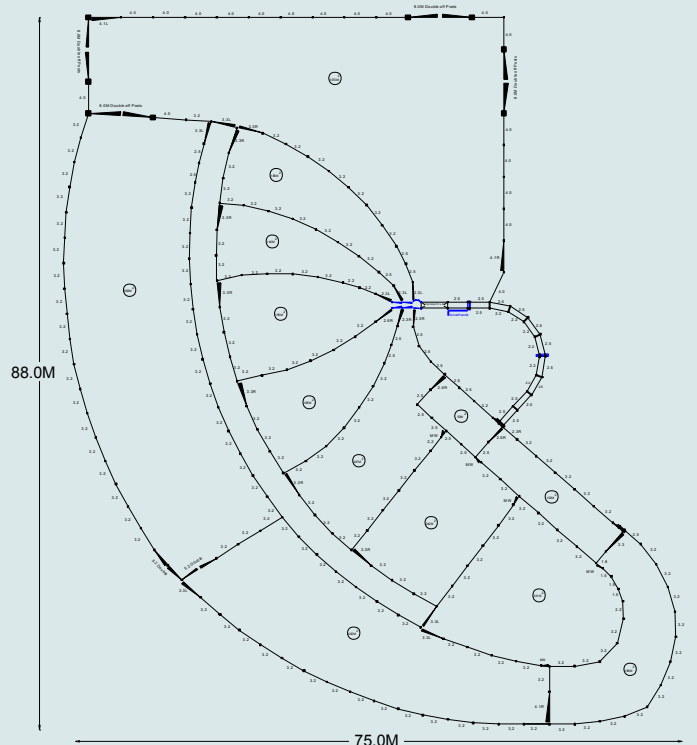

Total yard area is 5,400 square metres (work 2,100 head hold 3,000 head)

## Custom Design Service.

Andy Taylor from Scone required a second set of yards from us. Andy needed to work up to 500 dry cattle or 250 cows and calves. Factors to consider were the existing laneway, slope of the ground, a calf race where he could use his existing cradle, and preferred truck access. We adapted an existing plan that has resulted in all of Andy's requirements being met

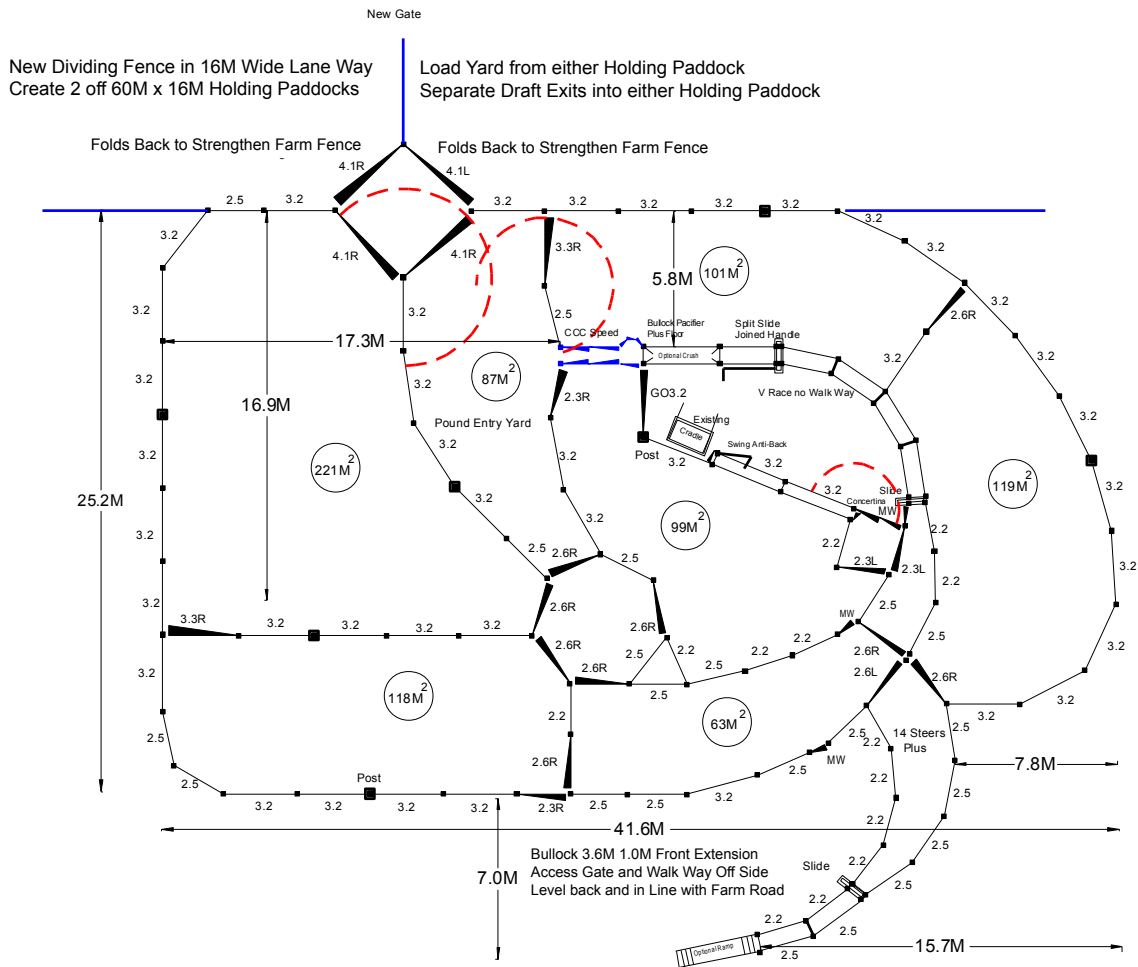

We also manufacture and sell farm an access grids. 4.0 Metres x 2.0 Metres x 415mm high. Rail gap 150mm (Black steel is painted silver).





## HOLDING YARDS/ROUND YARD CALCULATOR

PANELS	2.2 Metre		3.2 Metre		4.0 Metre	
	DiaMetre	Area sqm.	DiaMetre	Area sqm.	DiaMetre	Area sqm.
10	7.2	37	10.4	79	13.0	123
11	7.8	45	11.4	96	14.2	149
12	8.6	54	12.4	115	15.4	179
13	9.2	64	13.4	134	16.8	211
14	9.8	74	14.4	157	18.0	245
15	10.6	85	15.4	180	19.2	282
16	11.2	97	16.4	205	20.6	321
17	12.0	110	17.4	233	21.8	264
18	12.6	123	18.4	261	23.0	409
19	13.4	138	19.4	291	24.4	455
20	14.0	153	20.4	333	25.6	504
21	14.8	168	21.4	356	26.8	556
22	15.4	185	22.4	391	28.2	612
23	16.2	202	23.5	428	29.4	669
24	16.8	220	24.6	467	30.6	729
25	17.6	239	25.6	506	32.0	791
26	18.2	259	26.6	548	33.2	856
27	19.0	279	27.6	590	34.4	922
28	19.6	301	28.6	637	35.8	994
29	20.4	322	29.6	681	37.0	1067
30	21.0	346	30.6	729	38.2	1141

To calculate area requirements refer to page 23.

The table above refers to a complete round yard.

Example: 20 x 4.0m panels builds a **round** area of 504m<sup>2</sup>. 10 x 4.0m panels used as a **half moon** holding yard adjacent to an existing yard will have an area of 252m<sup>2</sup>.



# NATIONAL STOCKYARD SYSTEMS

37B Kyle Street, Rutherford NSW 2320

SIMON BURRELL  
Mobile 0425 257 865

NATHAN ELICOTT  
Mobile 0431 163 770

Telephone: (02) 4932 1363

[www.nationalstockyards.com.au](http://www.nationalstockyards.com.au)

